

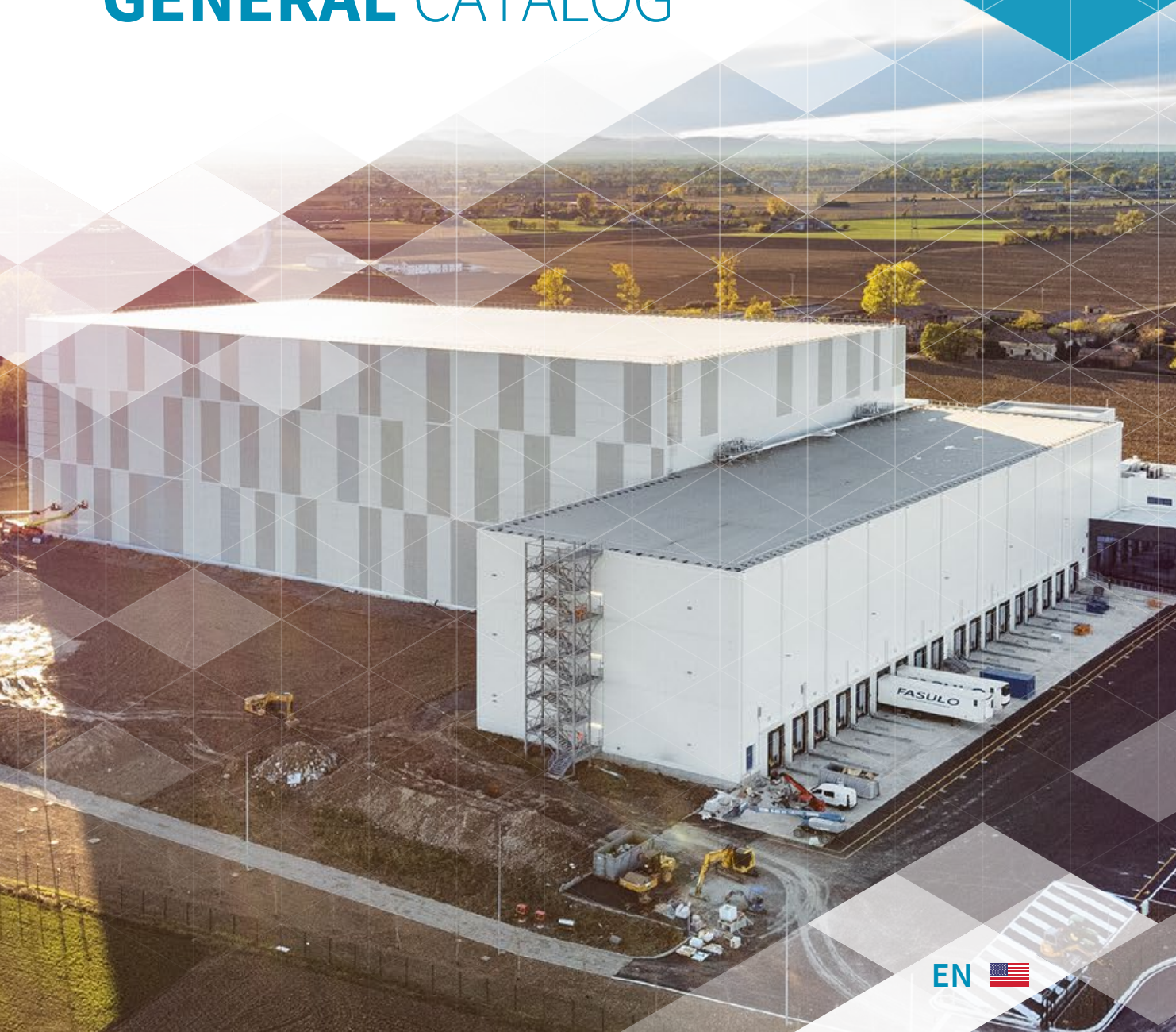

# GENERAL CATALOG









# INDEX

## About Us

International Leaders	7
Worldwide Facilities	8
Industries Application	9
We are Certified	10
Testing and Performance	11
Core Technologies	12
Fire and Acoustic	14
Color Chart	16

## Wall Panels

Isofort	18
Isoparete	20
Isoparete TPO / PVC	22
Isoparete Vinyl	24
Isobox / Super Isobox	26
Isobox TPO / PVC	28
Isobox Vinyl	30
Isofire Wall	32
Isofire Wall Fono	36

## Roof Panels

Isocop 4	40
Isodeck PVSteel	42
Isodeck Synth	44
Isofire Roof	46
Isofire Roof Fono	48

## Extra

Guidelines	50
Projects	52





# INTERNATIONAL LEADERS WITH THE POWER OF A GROUP

MANNI GROUP offers products, solutions and skills in dry construction building industry, promoting new scenarios to overcome energy waste and pollutant emissions in the existing building stock, through new buildings or retrofit renovations, helping Real Estate and Design Studios to achieve a higher value of the projects thanks to the environmental ethical principles and building know-how.



Marcegaglia Steel and Manni Group have signed an agreement for a joint venture in the insulated metal panels and sectional door panels sectors. This collaboration between two internationally renowned groups with a long tradition in steel processing has created a new industrial entity that will play a leading role in the Italian market and become the second-largest panel manufacturer in Europe, with a client portfolio spanning over 70 countries worldwide.

CINDU was founded in 1955 with the goal of offering industrial, commercial, and residential roofing and walls, as well as insulating and waterproofing panels in Latin America and the United States.



IsoCindu is the result of the partnership of two large industrial groups, Manni Group and Macegaglia from Italy through its subsidiary Isopan a world leader in IMP manufacturing, and Cindu, with several operations in America dedicated to supply a vast number of construction materials.

We operate the most technologically advanced and fully automated manufacturing facility in the Americas serving different industries with polyisocyanate, polyurethane and Mineral Wool with over 50 years of experience, we're recognized as the Americas leader in design, innovation and manufacturing of IMP's.



## WHY USE INSULATED METAL PANEL FOR YOUR PROJECTS?

**60%** Savings in energy, less quantity of air-conditioning

Smaller HVAC system requirement for maintaining the desired temperature. This can lead to cost savings in both equipment and operational expenses.

**50%** Reduction in time and crew construction labor

Construction crew can work more efficiently, potentially requiring fewer teams to install more square feet than traditional construction.

**25%** Savings in cost of equipment installation

The cost of lifting equipment, such as cranes or lifts, is a significant consideration. The size and weight of the IMPs reduces the cost of lifting equipment.

**50° f** Reduction of internal temperature

IMPs have a high R-value, providing effective insulation and reducing heat transfer. IMPs deliver better insulation compared to traditional construction materials.

# SEVERAL MARKETS A UNIQUE BRAND

Manni Group HP - Verona, Italy



Isopan Spa - Frosinone, Italy



Isopan Spa - Verona, Italy



Isopan Iberica - Tarragona, Spain

Isocindu - Silao, Mexico



Isopan Est - Popești Leordeni, București, Romania



# INDUSTRIES APPLICATION

## ► Cold Storage

Isocindu offers a wide range of options in panels that can deliver top performance in positive and negative cold rooms, temperature-controlled areas and clean rooms. In addition to their excellent performance, Isocindu panels lead to an excellent hygiene level thanks to easy cleaning and washable prepainted surfaces, unsuitable for the proliferation of fungi, bacteria and mold.



## ► Agriculture & Grow Rooms

Thanks to their high thermal insulation, resistance to mold, acids and mechanical movements, IsoCindu panels guarantee hygiene and safety for the farming or poultry sector and are environmentally integrated with the rural area in which they are located.



## ► Industrial & Data Centers

Isocindu panels are lightweight, safe and easy to install, providing the thermal insulation required for warehouses and industrial buildings, while also meeting the demanding standards of specialized projects such as data centers.



## ► Commercial / Health Care

Versatility, originality in design, safety, thermal insulation and easy assembly. The panel adapts to the different requirements of commercial buildings, allowing the maximum value of the commercial concept and brand to be projected.



## ► Architectural / Design

New trends in construction can be adapted with Isocindu panel systems. High technological performances are combined with aesthetic quality to offer more advantages in a single solution.



## ► Residential

Isocindu guarantees functional solutions for residential buildings of all styles, providing thermal insulation properties, safety, aesthetic value, respect for the environment, and the architectural landscape.

# WE ARE CERTIFIED

## Technology and Sustainability

We have a new-generation facility, which ensures a product of unbeatable quality that meets the toughest specifications and the best delivery times in the market.

IsoCindu has been replacing chlorofluorocarbons for more than 20 years with cyclopentane, an expanding agent that evaporates at the end of the expansion process without harming the atmosphere.

This contributes to the global challenge to improve the building sector based on an environmental sustainability perspective. Efficiency and energy savings guide IsoCindu's production management.

## Certifications

Our commitment to certifications stands as our initial promise to customers. Collaborating exclusively with certified suppliers ensures the adherence of primary materials to international quality standards.



Having earned the ISO 9001 certification, employing advanced technical product equality measures, being an active member of the Global Cold Chain Alliance, and taking the lead as a primary advocate for safety and quality in the refrigeration industry, we proudly extend the EPD (Environmental Product Declaration).

This designation reinforces our unwavering commitment to deliver envelope solutions that are not only energy-efficient and durable but also exemplify outstanding environmental performance.

## Associations

At Isocindu, we value the role that associations play in the construction and refrigeration industry. Therefore, we are proud to be members of the most important national and international associations in these sectors. We strive to actively participate in the activities and events of these associations to contribute our experience and expertise.



Our participation in associations allows us to stay updated on trends and technological advances in the industry. This allows us to offer our customers state-of-the-art products and services, as well as expert advice to solve any problems they may have.

# ESG REPORT 2024

Our Vision for a Sustainable Future

Scan to see ESG report



## ISOCINDU for Leed Certification

**LEED certification is linked to the measurement of the following features:**

- ▶ Water and energy resource consumption efficiency and the use of clean energy.
- ▶ Waste management and building materials used in the production and maintenance of the building.
- ▶ The quality of the building's interior environment.
- ▶ Space building optimization and environmental impact.
- ▶ Innovation and design, such as technologies and construction models used in building construction.

Our insulated panels for roofs and walls contribute to the prerequisites and credits for LEED BD+C (Building Design and Construction) V4 certification in the areas:

INTEGRATIVE PROCESS	IP	
SUSTAINABLE SITES	SS	
ENERGY AND ATMOSPHERE	EA	
MATERIALS AND RESOURCES	MR	
INDOOR ENVIRONMENTAL QUALITY	EQ	

# TESTING AND PERFORMANCE

TEST	Results	ROOF PANEL				WALL PANEL			
		Isocop	Isogrecata	Isodeck	Isovinile	Isoparete	Isofort	Isobox	Vinyl
<b>Enviromental Performance</b>									
<b>ASTM C518</b> Steady-state thermal transmission properties by means of the heat flow meter apparatus	PIR R-Value 7.87 at 35°F PIR R-Value 7.04 at 75°F	●	●	●	●	●	●	●	●
<b>Foam Core Characteristics</b>									
<b>ASTM D1621</b> Compressive Properties of Sandwich Core Materials	Compressive strength 17.4 psi to 10% compression	●	●	●	●	●	●	●	●
<b>ASTM C273</b> Shear properties of sandwich core materials	Shear strength 16 psi Results: 17.4 psi	●	●	●	●	●	●	●	●
<b>ASTM D1622</b> Apparent density of rigid cellular plastics	Density PUR 2 - 2.5 psf Density PIR 2.1 - 3.6 psf	●	●	●	●	●	●	●	●
<b>ASTM D1623</b> Tensile and tensile adhesion properties of rigid cellular plastics	Tensile Strength 17.4 psi	●	●	●	●	●	●	●	●
<b>Fire Resistance</b>									
<b>ASTM E84</b> Surface burning property of building material	Flame spread: 25 or less / Smoke developed: 450 or less	●				●	●	●	
<b>FM 4880</b> Approval standard for class 1 fire rating for wall, roof, and ceiling panels, interior finish materials, and exterior wall systems.	Class 1 fire rated Approval id: 0003056859	●				●	●	●	
<b>FM 4471</b> Approval standard for class 1 panel roofs	Class 1 fire rated approval id: 0003056859 approved for hail resistance, wind load and fire resistance	●							
<b>Impact Resistance</b>									
<b>FM 4881</b> Approval standard for class 1 exterior wall systems	Class 1 fire rated approval id: 0003056859 Adhesion strength of insulating foam to metal 2505.6 psf	●				●		●	
<b>Structural Components</b>									
<b>ASTM E84, FM 4471</b> FL42064 R0 COI Certification of Independence for Evaluation	FL42064 R0 II ESR-4659 FL42064 R0 C CAC FM	●							
<b>Engineering Properties</b>									
<b>FM 4881</b> Approval standard for class 1 panel roofs	Class 1 fire rated approval id: 0003056859	●				●		●	
<b>ICC- ES EVALUATION</b> Division: 07 00 00 - Thermal and moisture protection Section 07 40 00 - Roofing and siding panels Apply in 2" to 8" panel thickness and PIR foam		●				●			

# CORE TECHNOLOGIES

## PUR & PIR CORE:

### Insulated Core Options for Several Projects

**PUR:** Ideal performance in thermal insulation and high resistance, due to the isocyanate and polyol mix, generating an expansion of material and filling the cells with gas, this achieves a temperature insulation and improves energy efficiency. Density: 2.49 LB/FT<sup>3</sup> - R-Value per inch: 6.6.

**PIR (Polyisocyanurate):** Is a mixture of polyol, isocyanate and cyclopentane. Designed for industrial construction and refrigeration. PIR foam has higher fire resistance, low smoke emission and maintains its insulating thermal conductivity. Density: 2.6 LB/FT<sup>3</sup> - R-Value per inch 7.0.

## PIR R-PLUS

### The Next Step in PIR Foam Insulated Technology.

Engineered with a unique advanced Polyisocyanurate (PIR) core, developed by Isocindu, R-Plus sets a new standard for thermal performance by providing **7.5 R-Value per inch**.

**Versatile and Advanced PIR Formula:** This advanced core technology contributes up to 8% to 14% higher R-value compared to the average of the polyisocyanurate market leaders, minimizing heat loss and reducing the energy cost operation for heating or cooling equipment, providing excellent insulation performance across a wide range of projects, but most important in cold storage projects.

## Leaf

### The Most Advanced Insulation Technology

Most Advanced Insulation: **LEAF enhances the thermal performance with 7.9 R-Value per inch**, reducing the foam's thermal conductivity. With a lambda reduction up to 20% and a one-inch difference in thickness, it enables lower thermal transmittance compared to standard products. This leads to reduced transportation costs, building weight and volume while creating additional usable space within the building.

**Safe and Sustainability:** Leaf delivers high fire performance without the use of hazardous halogenated flame retardants. It has achieved B-s1, d0 fire rating, the highest for polyurethane panels, this certification indicates minimal smoke production in the event of fire, as well as the absence of flaming drips or particles.

## CORE TECHNOLOGY COMPARISON

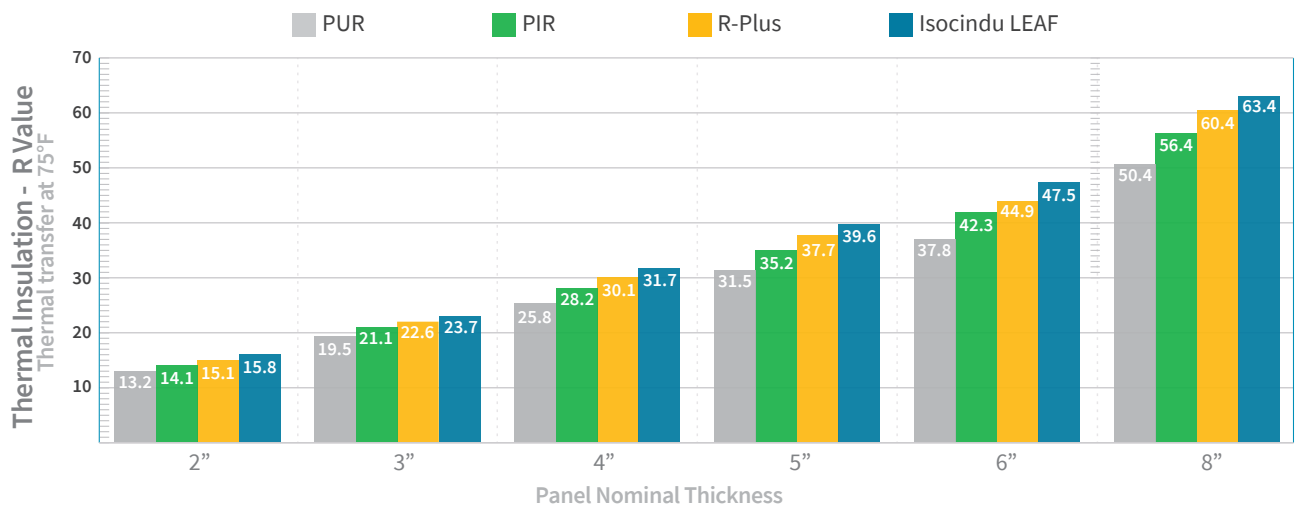

# MINERAL WOOL

## Superior Performance and Fire Resistance

In order to offer solutions that improve fire protection and acoustic performance of buildings, Isocindu offers insulated metal panels with mineral wool core, with the reliability that they comply with current regulations and legislations on fire and acoustic insulation.

Mineral wool panels have been subjected to different tests that allow certifying the acoustic performance and reaction to fire EI and REI of each of the solutions.

Mineral wool is a recyclable insulating material that offers superior energy efficiency. This means several benefits. First, it ensures optimal thermal comfort within a building, reducing the need for heating and cooling.

Second, as a fire-resistant material, it slows the spread of flames, providing valuable time for evacuation in the event of a fire.

Finally, mineral wool provides excellent acoustic insulation, with noise reduction of up to 36dB (or up to 53dB with combined panel systems). This effectively prevents external noise from entering the building and internal noise from escaping.



### Thermal Insulation

According to standard EN 14508 A.10

U	50	60	80	100	120	150	170	200	240
W/m <sup>2</sup> ·K	0.75	0.63	0.49	0.39	0.33	0.27	0.24	0.20	0.17
Kcal/m <sup>2</sup> ·h·°C	0.65	0.54	0.42	0.34	0.28	0.23	0.21	0.17	0.15
K	50	60	80	100	120	150	170	200	240
W/m <sup>2</sup> ·K	0.75	0.64	0.50	0.40	0.33	0.27	0.24	0.20	0.17
Kcal/m <sup>2</sup> ·h·°C	0.67	0.55	0.40	0.35	0.30	0.24	0.21	0.17	0.15

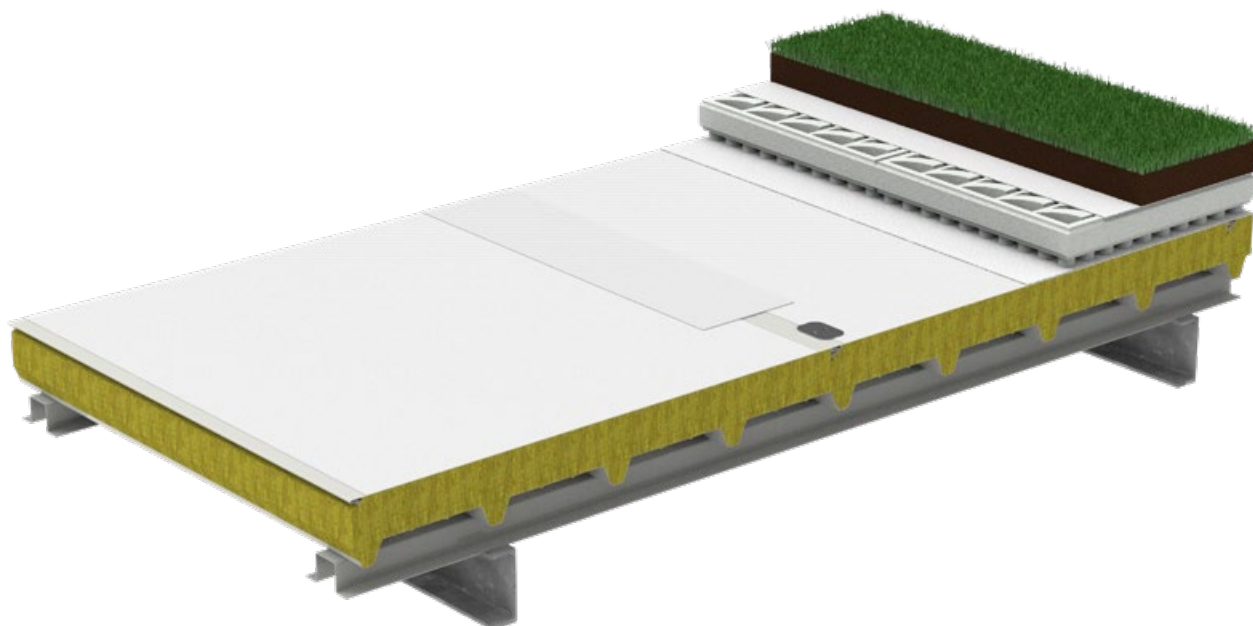

# FIRE AND ACOUSTIC PERFORMANCE

## Fire Reaction

Certification	Core	Panel	Panel nominal thickness (mm - in)												
			30 1"	35	40 1½"	50 2"	60 2½"	80 3"	100 4"	120	140	150 6"	170	200 8"	240
Roof Panel															
A2 s1 d0	MW	Isofire Roof				●	●	●	●	●		●	●	●	
A2 s1 d0	MW	Isofire Roof Fono				●	●	●	●	●		●	●	●	
B s1 d0 <sup>1</sup>	MW	Isodeck PVSteel				●	●	●	●	●		●	●	●	
B s1 d0 <sup>1</sup>	PIR	Isocop	●		●	●	●	●	●	●		●			
B s2 d0	PIR	Isocop	●		●	●	●	●	●	●		●			
B s2 d0	PIR	Isodeck PVSteel	●		●	●	●	●	●	●		●			
B s3 d0	PUR	Isocop	●		●	●	●		●	●		●			
C s3 d0	PUR	Isocop							●	●		●			
C s3 d0	PUR	Isodeck PVSteel	●		●	●	●		●	●		●			
Wall Panel															
A2 s1 d0	MW	Isofire Wall				●	●	●	●	●		●	●	●	●
A2 s1 d0	MW	Isofire Wall Fono				●	●	●	●	●		●	●	●	●
A2 s1 d0	MW	Isofire Wall Striated				●	●	●	●	●		●	●		
B s1 d0 <sup>1</sup>	PIR	Isobox	●	●	●	●	●	●	●	●					
B s1 d0 <sup>1</sup>	PIR	Isoparete			●	●	●	●	●	●		●			
B s2 d0	PIR	Isobox / Isopiano	●	●	●	●	●	●	●	●		●			
B s2 d0	PIR	Isoparete			●	●	●	●	●	●		●			
B s2 d0	PUR	Isoparete			●	●	●	●	●	●		●			
B s3 d0	PUR	Isobox / Isopiano	●	●	●	●	●	●	●	●					

## Acoustic Insulation

Certification	Core	Panel	Panel nominal thickness (mm - in)													
			30 1"	35	40 1½"	50 2"	60 2½"	80 3"	100 4"	120	140	150 6"	170	200 8"	240	
Roof Panel																
RW = 36 dB	MW	Isofire Roof Fono							●						●	
RW = 35 dB	MW	Isofire Roof Fono							●							
RW = 34 dB	MW	Isofire Roof Fono								●	●		●	●	●	
RW = 31 dB	MW	Isofire Roof Fono				●	●						●	●	●	
RW = 34 dB	MW	Isofire Roof													●	
RW = 30 dB	MW	Isofire Roof				●										
RW = 29 dB	PIR	Isocop								●	●		●			
Wall Panel																
RW = 35 dB	MW	Isofire Wall Fono							●	●	●		●	●	●	
RW = 34 dB	MW	Isofire Wall Fono				●	●									
RW = 34 dB	MW	Isofire Wall											●	●	●	●
RW = 30 dB	MW	Isofire Wall							●	●	●		●	●	●	●
RW = 29 dB	PIR	Isoparete Striated								●	●	●				

By combining different panels, each with its own RW value, it is possible to achieve up to a 50 dB sound reduction in the project. For further technical information or assistance in determining the optimal panel configuration, please contact your sales representative or our technical department.

## Fire Resistance

Certification	Core	Panel	Panel nominal thickness (mm)												
			30 1"	35	40 1½"	50 2"	60 2½"	80 3"	100 4"	120	140	150 6"	170	200 8"	240
Roof Panel															
REI 240	MW	Isofire Roof												●	
REI 180	MW	Isofire Roof <sup>1</sup>						●	●		●	●			
REI 120	MW	Isofire Roof						●	●		●	●			
REI 120	MW	Isofire Roof Fono							●		●	●	●		
REI 120	MW	Isodeck PVSteel							●		●	●	●		
REI 60	MW	Isofire Roof						●							
REI 60	MW	Isofire Roof Fono						●	●		●	●	●		
REI 30	MW	Isofire Roof				●	●								
REI 30	PIR	Isocop <sup>1</sup>						●	●		●				
REI 15	PIR	Isodeck PV Steel <sup>1</sup>						●	●		●				
REI 15	PIR	Isocop <sup>1</sup>					●	●	●						
REI 15	PUR	Isocop <sup>1</sup>						●	●	●		●			
Wall Panel															
EI 180	MW	Isofire Wall / Fono										●	●	●	●
EI 120 <sup>1</sup>	MW	Isofire Wall / Fono						●	●		●	●	●	●	●
EI 90	MW	Isofire Wall / Fono							●		●	●	●	●	●
EI 60	MW	Isofire Wall						●	●						
EI 30 <sup>1</sup>	MW	Isofire Wall / Fono				●	●								
EI 30 <sup>1</sup>	MW	Isofire Wall Striated						●	●		●	●			
EI 30 <sup>1</sup>	PIR	Isobox / Isopiano						●	●						
EI 20 <sup>1</sup>	PIR	Isobox / Isopiano					●	●	●	●					
EI 20 <sup>1</sup>	PIR	Isoparete						●	●	●					
EI 15	MW	Isofire Wall / Fono				●	●								
EI 15	PIR	Isobox / Isopiano					●	●	●	●					
EW 240 <sup>1</sup>	MW	Isofire Wall										●	●	●	
EW 60 <sup>1</sup>	PUR	Isobox / Isopiano						●	●	●					

## Acoustic Absorption

Certification	Core	Panel	Panel nominal thickness (mm)												
			30 1"	35	40 1½"	50 2"	60 2½"	80 3"	100 4"	120	140	150	170	200 8"	240
Roof Panel															
α W = 1	MW	Isofire Roof Fono				●	●	●	●	●		●	●	●	
α W = 1	MW	Isodeck PVSteel Fono				●	●	●	●	●		●	●	●	
Wall Panel															
α W = 1	MW	Isofire Wall Fono				●	●	●	●	●		●	●	●	

● Certificate with extension    ● Performance available with technical note

The performances stated in the following tables, associated with the different types of insulation, may vary according to the production plant, in accordance with the local and national regulations in force. For further details, please contact Isocindu's technical department. If not expressly requested, performance will not be provided.

Reaction to Fire Classes in accordance with EN 13501-1 y EN 14509/2013.

Fire resistance in accordance with EN 13501-2 y EN 14509/2013.

Achievable performance by following the assembly instructions correctly.

An αw certificate refers to a certification for a building product as an acoustic panel that indicates its weighted sound absorption coefficient (αw)

(<sup>1</sup>) Special Formula - Contact IsoCindu

# COLOR CHART

## Category 1 - Stock Colors

Standard Color Steel / Polyester Standard / USDA / G60



RAL 9002  
White Grey  
Emissivity: 0.85  
SRI: 80.00

RAL 9010  
Pure White  
Emissivity: 0.86  
SRI: 72.00

SIMIL RAL 9003  
Signal White

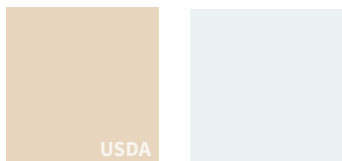

Standard Sand

Pyrenean White

## Category 2 / Kynar / G90

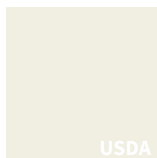

All Category 2 can be developed in same colors of Category 1 and special colors

Emissivity: 0.86  
SRI: 72.00

RAL 9010  
Pure White

Coatings are durable polyvinylidene systems containing 70% Kynar or Hylar resins, ceramic and other inorganic pigments. This system provides a powerful chemical bond, resistance to ultraviolet radiation with exceptional color retention, chalking resistance, and chemical degradation, 20 years warranty.

## Category 3 / Special Coating or Finish



USDA Steel (24, 26, gauge)



Corten Steel



Antibacterial Steel



Stainless Steel

## Special Colors Category

No Stock Colors / Polyester Standard / USDA / G60



SIMIL RAL 6028  
Pine Green

SIMIL RAL 7016  
Anthracite Grey

SIMIL RAL 5010  
Genecian Blue  
Emissivity: 0.85  
SRI: 28.00

SIMIL RAL 3020  
Carmine Red



RAL 2004  
Pure Orange

SIMIL RAL 3009  
Oxide Red

SIMIL RAL 9006  
Silver Grey  
Emissivity: 0.72  
SRI: 48.00

RAL 8004  
Copper Brown



Special Blue

Ixtapa Blue

Royal Blue

Metalic Grey



Pantone Green

Grass Green

Special colors are not standard stock colors. Additional lead time and costs may apply upon request.

## Salt Spray

	Polyester	Super Polyester	PVDF	FEVE
Salt Spray	1,000 hrs	1,000 and 2,000 hrs	2,000 and 3,000 hrs	1,000 and 3,000 hrs

When selecting panel faces, it is crucial to consider their exposure to different environments. The external face is subject to atmospheric pollutants, sunlight, and UV rays, which raise the metal temperature and trigger reactions in the organic coating. In contrast, the insulated internal face remains cooler but must resist pollutants and chemical agents from production processes. Pre-lacquered steel typically consists of a zinc base coat, primer, and finish coats.

IMPORTANT: For stock availability, thickness, supports, non-standard colors and guarantees, contact IsoCindu. Colors may vary depending on the batch of numeric codes that correspond to the most similar RAL code. \*Custom colors will be an up charged / Confirm steel chart last date version. For special guarantees, please refer to your commercial agent to fill out the customer environmental questionnaire. Colours: \*Match the original colours within the limitations of printing

The image features a background of window blinds with a grid pattern overlaid. A large white arrow points from the left towards the center, where the text is located. The text is in a bold, blue, sans-serif font.

# Wall Panel

### Double Joint Concealed Fastener

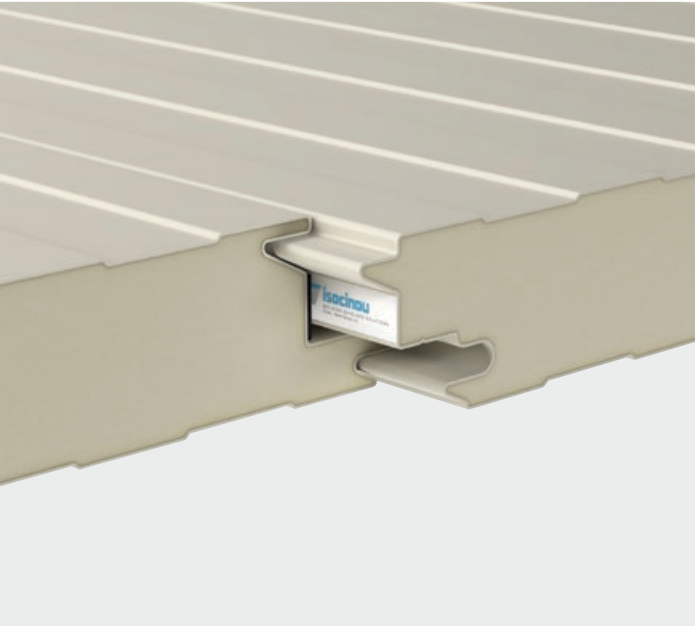

### Features

A double-steel sheet wall panel, with polyisocyanurate rigid foam. Advanced double-joint system and internal and external mechanical seals ensure exceptional performance, including a high load capacity. External faces available in striated, box, and flat profiles. The internal face is standard with the box profile, embossed or unembossed.

### Options

Isofort is available in thicknesses from 2.5" to 8", panel width of; Isofort Pro 36", Isofort 39" and Isofort Plus 42", in 22, 24, or 26 gauge to meet a variety of project requirements. Engineered to withstand harsh weather conditions, it features a concealed joint for a seamless, watertight finish.

### Benefits

- Double joint advanced design
- 3 different standard widths
- Internal and external mechanical seals
- High thermal resistance for controlled temperatures
- Up to 8" thick

### Specifications

<b>Length:</b>	Maximum of 53'
<b>Width:</b>	★ Isofort Pro 36" / Isofort 39" / Isofort Plus 42"
<b>Thickness:</b>	2½" 3" 4" 5" 6" 8"
<b>Foam Core:</b>	PUR, PIR, PIR R+, Leaf (Best R value) 2.62 - 2.49 LB/FT <sup>3</sup>
<b>Joint Type:</b>	Tongue and Groove - Hidden
<b>Gasket:</b>	Open Cell Gasket - Butyl available upon request
<b>Steel Gauge:</b>	External: 22, 24, 26 - Internal: 22, 24, 26, 28
<b>Coating:</b>	Polyester Std. G60, Kynar G90, Stainless Steel 314
<b>Std. Coating:</b>	USDA Approved
<b>Orientation:</b>	Vertical - Horizontal

Other paint systems available upon demand. For trims and accessories, ask your sales rep or contact Isocindu for more information and availability.

### Suitable for

- Industrial:** Warehouse, Factories, Distribution Centers
- Cold Chain:** Cold Chambers, Freezers, Cold Chain facilities
- Commercial:** Offices, Malls, Hotels, Healthcare facilities
- Architectural:** Schools, Museums, Government, Transport hubs
- Specialized:** Airports, Green Building, Data Centers, Stadiums

### Face Profiles

Striated and flat profiles, it's recommended to use 24 gauge or higher.

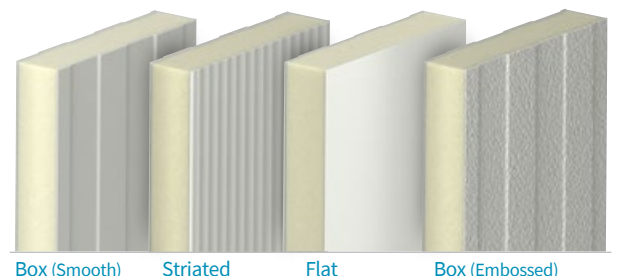

### Double Joint Concealed Fastener

#### Load Chart

Isofort Pro (36") 2 Simple Supports						
PSF	20	25	30	35	40	45
Thickness	26/26 Ga - PIR with 10% Safety Factor - PSF Values					
2½"	10'-4"	8'-2"	6'-6"	6'-4"	6'-1"	5'-10"
3"	10'-5"	8'-4"	6'-8"	6'-6"	6'-2"	6'-1"
4"	10'-11"	8'-10"	6'-10"	6'-8"	6'-4"	6'-2"
5"	11'-1"	9'-2"	7'-1"	6'-10"	6'-6"	6'-4"
6"	11'-5"	9'-4"	7'-2"	7'-1"	6'-8"	6'-4"
8"	12'-1"	9'-6"	7'-4"	7'-4"	7'-2"	6'-10"

Isofort (39") 2 Simple Supports						
PSF	20	25	30	35	40	45
Thickness	26/26 Ga - PIR with 10% Safety Factor - PSF Values					
2½"	7'-4"	7'-1"	6'-8"	6'-6"	6'-4"	6'-2"
3"	7'-6"	7'-2"	6'-10"	6'-8"	6'-6"	6'-4"
4"	7'-8"	7'-6"	7'-2"	7'-1"	6'-10"	6'-6"
5"	8'-1"	7'-8"	7'-6"	7'-2"	7'-2"	6'-10"
6"	8'-4"	8'-1"	7'-8"	7'-6"	7'-4"	7'-2"
8"	8'-10"	8'-6"	8'-1"	8'-1"	7'-10"	7'-8"

Isofort Plus (42") 2 Simple Supports						
PSF	20	25	30	35	40	45
Thickness	26/26 Ga - PIR with 10% Safety Factor - PSF Values					
2½"	6'-6"	6'-4"	6'-2"	6'-1"	6'	5'-10"
3"	6'-8"	6'-6"	6'-4"	6'-2"	6'-1"	6'-1"
4"	6'-10"	6'-8"	6'-6"	6'-6"	6'-2"	6'-2"
5"	7'-1"	6'-10"	6'-8"	6'-8"	6'-4"	6'-4"
6"	7'-2"	7'-1"	6'-10"	6'-10"	6'-6"	6'-6"
8"	7'-8"	7'-4"	7'-2"	7'-1"	7'-1"	6'-10"

Simple span and multi-span charts are available. Please contact your sales representative for more information.

#### Thermal Insulation

Thickness	2½"	3"	4"	5"	6"	8"
Value	PIR R+ 75° F Mean Temp (95° to 55°) ASTM C518					
U (Btu/H ft² F)	0.05	0.04	0.03	0.02	0.02	0.01
R (H ft² F/Btu)	18.8	22.6	30.1	37.7	44.9	60.4
Value	PIR R+ 35° F Mean Temp (55° to 15°) ASTM C518					
U (Btu/H ft² F)	0.04	0.04	0.03	0.02	0.02	0.01
R (H ft² F/Btu)	20.8	25.2	33.7	42.1	50.5	67.4

#### Panel Weight

Steel Thickness	Panel Nominal Thickness (in) - Isofort (39")					
	2½"	3"	4"	5"	6"	8"
26/26	lb/ft 7.39	7.72	8.33	8.93	9.47	10.68
24/24	lb/ft 8.60	8.93	9.47	10.07	10.68	11.89

#### Dimensional Tolerance

Lenght	L ≤ 9' 10" ± 1/8" L > 9' 10" ± 3/8"	Perpendicularity Deviation	1/4"
Working Lenght	± 1/16"	Misalignment of the internal metal surfaces	± 1/8"
Thickness	D ≤ 4" ± 1 1/16" D > 4" ± 2 %	Bottom Sheet Coupling	F = 1 + 1/8"

L = working length, D = panel thickness, F = sheet coupling

#### Important Notes

- The results are considered without any fasteners (Fablock/clamping screws).
- The results were considered with a maximum deflection of L/180.
- The results do not take into account the thickness of the supports or the fastening method. The results exclude the temperature differential.

This load chart does not apply to ceilings. Project-specific load calculation requirements must be determined by design team and/or structural engineer. Charts are reference only, contact Isocindu's technical area for more information

#### Fixing System

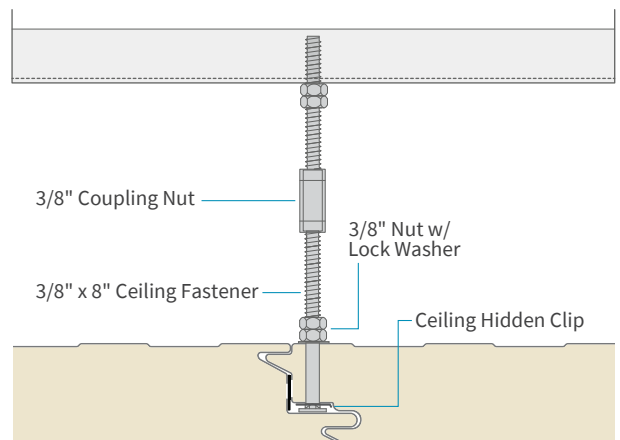
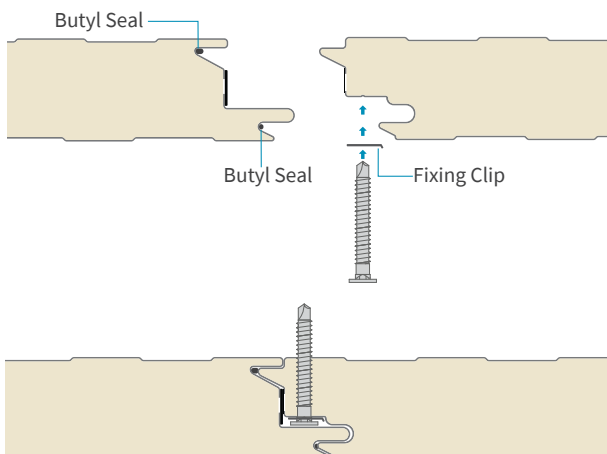

### Concealed Fastener



### Features

A double-steel sheet wall panel, insulated with polyisocyanurate rigid foam. The tongue-and-groove joint completed by concealed fasteners and saddle clip. External faces are available in striated, box, and flat profiles. The internal face is standard with the box profile (contact us for other options).

### Options

Isoparete is a sandwich panel characterized by a hidden fixing joint system, used for industrial and commercial building walls, and perfect solution for cold storage industries. Available with butyl seal placed in plant.

### Benefits





- Gasket barrier to prevent vapor leaks
- High mechanical strength & puncture resistance
- High thermal resistance for controlled temperatures
- Up to 8" thick
- Possibility of combination with compatible panels

### Specifications

<b>Length:</b>	Maximum of 53'
<b>Width:</b>	★ 39 3/8"
<b>Thickness:</b>	1 1/8" 2" 2 1/2" 3" 4" 5" 6" 8"
<b>Foam Core:</b>	PUR, PIR, PIR R+, Leaf (Best R value) 2.62 - 2.49 LB/FT <sup>3</sup>
<b>Joint Type:</b>	Tongue and Groove - Hidden
<b>Gasket:</b>	Open Cell Gasket - Butyl available upon request
<b>Steel Gauge:</b>	<b>External:</b> 22, 24, 26 - <b>Internal:</b> 22, 24, 26, 28
<b>Coating:</b>	Polyester Std. G60, Kynar G90, Stainless Steel 314
<b>Std. Coating:</b>	USDA Approved
<b>Orientation:</b>	Vertical - Horizontal

Other paint systems available upon demand. For trims and accessories, ask your sales rep or contact Isocindu for more information and availability.

### Suitable for

-  **Industrial:** Warehouse, Factories, Distribution Centers
-  **Cold Chain:** Cold Chambers, Freezers, Mid Size Labs
-  **Commercial:** Office, Retail, Restaurants
-  **Architectural:** Schools, Museums, Government
-  **Specialized:** Airports, Green Building

### Face Profiles

Striated and flat profiles, it's recommended to use 24 gauge or higher.

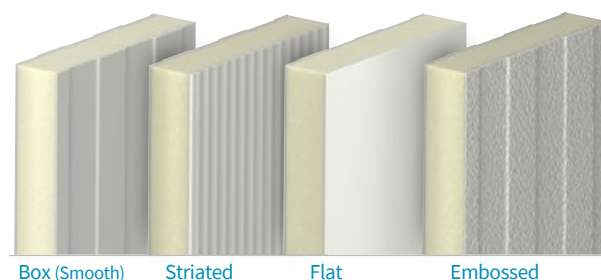

### Concealed Fastener

#### Load Chart

Distance Between 2 Simple Supports							
PSF	16	20	24	28	32	36	40
Thickness	26/26 Ga - PIR with 10% Safety Factor - PSF Values						
1½"	8'-6"	7'-6"	6'-10"	6'-2"	5'-8"	5'-4"	5'-1"
2"	10'-2"	9'-0"	8'-2"	7'-6"	6'-10"	6'-4"	6'-1"
2½"	11'-5"	10'-5"	9'-6"	8'-8"	8'-1"	7'-6"	7'-1"
3"	13'-7"	12'-3"	11'-1"	10'-2"	9'-6"	9'	8'-4"
4"	16'-1"	14'-9"	13'-7"	12'-7"	11'-11"	11'-3"	10'-7"
5"	18'-8"	17'-10"	15'-7"	14'-7"	13'-7"	12'-11"	12'-3"
6"	20'-8"	18'-8"	17'-2"	15'-8"	15'-1"	15'-1"	13'-5"
8"	25'-5"	23'-3"	21'-1"	19'-8"	18'-10"	17'-8"	16'-6"

Distance Between Multiple Supports							
PSF	16	20	24	28	32	36	40
Thickness	26/26 Ga - PIR with 10% Safety Factor - PSF Values						
1½"	9'-6"	8'-6"	7'-6"	7'-6"	6'-6"	5'-2"	4'-9"
2"	11'-5"	10'-2"	9'-2"	8'-2"	7'-2"	6'-6"	5'-10"
2½"	13'-5"	11'-9"	10'-5"	9'-8"	8'-8"	7'-10"	7'-1"
3"	15'-7"	13'-9"	12'-1"	11'-1"	10'-2"	9'-4"	8'-8"
4"	17'-2"	15'-5"	13'-7"	12'-5"	11'-7"	11'-1"	10'-4"
5"	18'-8"	16'-1"	14'-7"	13'-5"	12'-3"	11'-7"	10'-11"
6"	24'-3"	20'-11"	18'-2"	16'-6"	15'-1"	13'-9"	13'-1"
8"	24'-7"	22'-5"	19'-4"	17'-4"	15'-7"	13'-11"	13'-5"

#### Panel Weight

Steel Gauge	Panel Nominal Thickness (in)							
	1½"	2"	2½"	3"	4"	5"	6"	8"
26/26 PSF	2.07	2.14	2.24	2.33	2.52	2.70	2.89	3.27
24/26 PSF	2.44	2.51	2.61	2.70	2.85	3.04	3.26	3.64
24/24 PSF	2.78	2.85	2.94	3.04	3.22	3.41	3.60	3.97
22/26 PSF	2.72	2.70	2.88	2.98	3.16	3.35	3.54	3.91

#### Dimensional Tolerance

Length	$L \leq 9' 10" \pm \frac{1}{8}"$	Perpendicularity Deviation	$\frac{1}{4}"$
	$L > 9' 10" \pm \frac{3}{8}"$		
Working Length	$\pm \frac{1}{16}"$	Misalignment of the internal metal surfaces	$\pm \frac{1}{8}"$
Thickness	$D \leq 4" \pm 1 \frac{1}{16}"$	Bottom Sheet Coupling	$F = 1 + \frac{1}{8}"$
	$D > 4" \pm 2 \%$		

L = working length, D = panel thickness, F = sheet coupling

#### Thermal Insulation

Thickness	1½"	2"	2½"	3"	4"	5"	6"	8"
Value	PIR R+ 75° F Mean Temp (95° to 55°) ASTM C518							
U (Btu/H ft² F)	0.08	0.06	0.05	0.04	0.03	0.02	0.02	0.01
R (H ft² F/Btu)	12.3	15.1	18.8	22.6	30.1	37.7	44.9	60.4
Value	PIR R+ 35° F Mean Temp (55° to 15°) ASTM C518							
U (Btu/H ft² F)	0.07	0.05	0.04	0.04	0.03	0.02	0.02	0.01
R (H ft² F/Btu)	13.8	16.8	20.8	25.2	33.7	42.1	50.5	67.4

#### Important Notes

"The load chart above does not apply to ceilings. Project-specific load calculation requirements must be determined by the design team and/or structural engineer.

- 1.- The results are considered without any fasteners (Fablock/clamping screws).
- 2.- The results were considered with a maximum deflection of L/180.
- 3.- The results do not take into account the thickness of the supports or the fastening method. The results exclude the temperature differential.
- 4.- For extendable load chart contact technical department



Isoparete box, striated and Flat, are FM (Factory Mutual) certified only in thicknesses from 1½" to 6", in standards 4880 and 4881.



Isoparete evaluation apply from 2" to 8" with PIR foam in Division: 07 00 00 - Thermal and moisture protection, and Section: 07 40 00 - Roofing and siding panels.

#### Expansion Joint

Profile Option 1: No Gap Between

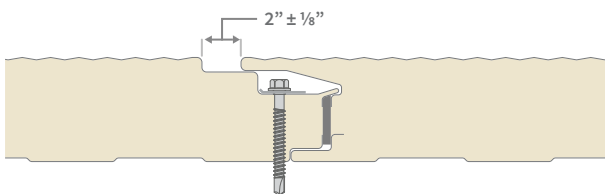

Standard Gap  $\frac{1}{8}"$ , recommended to select the expansion joint in dark colors (L<75) to reduce thermal expansion.

Profile Option 2: No Gap Between

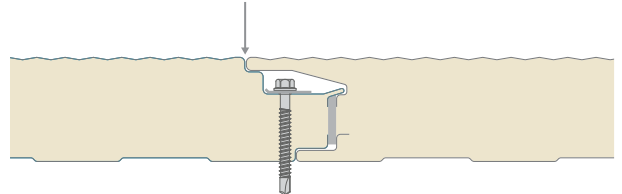

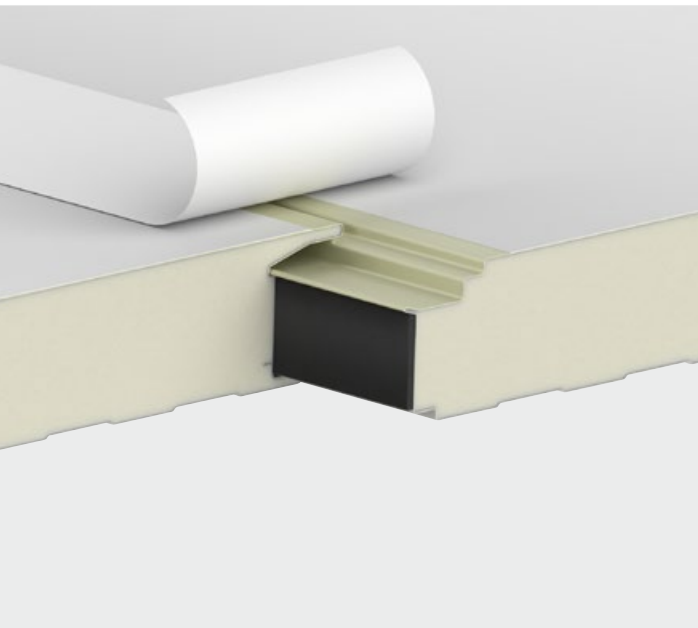

## Specifications

<b>Length:</b>	Maximum of 53'
<b>Width:</b>	★ 39 3/8"
<b>Thickness:</b>	1 1/2" 2" 2 1/2" 3" 4" 5" 6" 8"
<b>Foam Core:</b>	PUR, PIR, PIR R+, Leaf (Best R value) 2.62 - 2.49 LB/FT <sup>3</sup>
<b>Joint Type:</b>	Tongue and Groove - Hidden
<b>Gasket:</b>	Open Cell Gasket - <i>Butyl available upon request</i>
<b>Steel Gauge:</b>	<b>External:</b> 22 - <b>Internal:</b> 22, 24, 26, 28
<b>External Face:</b>	PVC/TPO Coated Metal Base
<b>Internal face:</b>	Pre-painted Coated Steel (ASTM A653)
<b>Std. Coating:</b>	USDA Approved
<b>Orientation:</b>	Vertical - Horizontal

Other paint systems available upon demand. For trims and accessories, ask your sales rep or contact Isocindu for more information and availability.

## Features

This system is our isoparete wall panel with external face in TPO or PVC, a single PLY membrane system.

The TPO is composed of a thermoplastic waterproofing membrane, characterized by the absence of plasticizers and halogens, giving resistance to aging, UV rays, and atmospheric agents making. The synthetic PVC-P is a light gray top layer, highly resistant to atmospheric agents and UV rays.

## Options





Isoparete TPO / PVC is an affordable panel that provides a better internal view, thermal insulation, and easy cleaning, with functional quality. Available with butyl seal placed in plant.

## Benefits

**TPO:** Lightweight, UV-resistant, flexible, and cost-effective, ideal for energy efficiency and solar reflectivity requirements.

**PVC:** Strong, fire-retardant, chemically resistance and long lasting. Perfect for industrial, hygienic or safety applications

## Suitable for

-  **Industrial:** Warehouse, Factories, Distribution Centers
-  **Cold Chain:** Cold Chambers, Freezers, Cold Chain Facilities
-  **Commercial:** Offices, Malls, Convention Centers
-  **Architectural:** Schools, Government, Transport hubs
-  **Specialized:** Flat Roofs, Green Building, Data Centers



External Face



Internal Face

### TPO & PVC Steel Concealed Fastener

#### Panel Weight

Steel Thickness		Panel Nominal Thickness (in)						
		2"	2½"	3"	4"	5"	6"	8"
26/26	PSF	2.14	2.24	2.33	2.52	2.70	2.89	3.27
24/26	PSF	2.51	2.61	2.70	2.85	3.04	3.26	3.64
24/24	PSF	2.85	2.94	3.04	3.22	3.41	3.60	3.97
22/26	PSF	2.70	2.88	2.98	3.16	3.35	3.54	3.91

#### Thermal Insulation

Thickness	1½"	2"	2½"	3"	4"	5"	6"	8"
Value	PIR R+ 75° F Mean Temp (95° to 55°) ASTM C518							
U (Btu/H ft² F)	0.08	0.06	0.05	0.04	0.03	0.02	0.02	0.01
R (H ft² F/Btu)	12.3	15.1	18.8	22.6	30.1	37.7	44.9	60.4
Value	PIR R+ 35° F Mean Temp (55° to 15°) ASTM C518							
U (Btu/H ft² F)	0.07	0.05	0.04	0.04	0.03	0.02	0.02	0.01
R (H ft² F/Btu)	13.8	16.8	20.8	25.2	33.7	42.1	50.5	67.4

#### Load Chart

To obtain specific information about the panel's load capacity values, please contact an authorized Isocindu sales representative or technical specialist.

#### Dimensional Tolerance

Lenght	L ≤ 9' 10" ± 1/8" L > 9' 10" ± 3/8"	Perpendicularity Deviation	1/4"
Working Lenght	± 1/16"	Misalignment of the internal metal surfaces	± 1/8"
Thickness	D ≤ 4" ± 1 1/16" D > 4" ± 2 %	Bottom Sheet Coupling	F = 1 + 1/8"

L = working length, D = panel thickness, F = sheet coupling

#### Joint Section

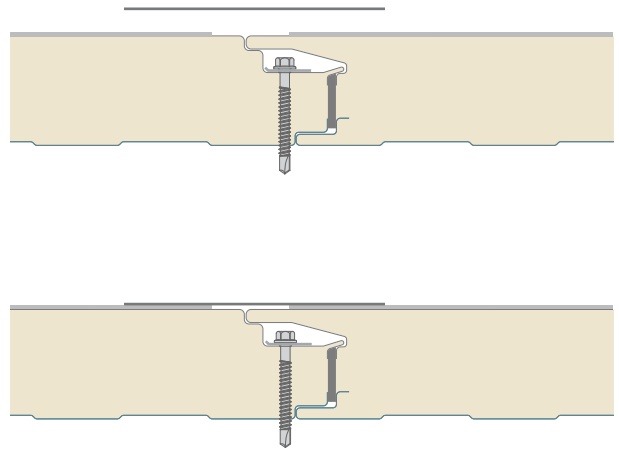

### Concealed Fastener

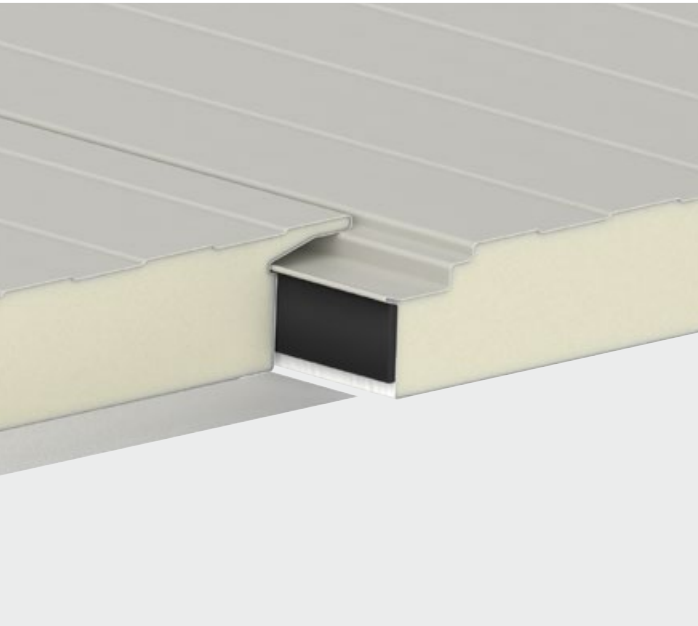

### Specifications

<b>Length:</b>	Maximum length of 20'
<b>Width:</b>	★ 39 3/8"
<b>Thickness:</b>	1 1/4" 1 5/8" 2" 2 1/2"
<b>Foam Core:</b>	PUR, PIR, PIR R+, Leaf (Best R value) 2.62 - 2.49 LB/FT <sup>3</sup>
<b>Joint Type:</b>	Tongue and Groove - Hidden
<b>Gasket:</b>	Open Cell Gasket - <i>Butyl available upon request</i>
<b>Steel Gauge:</b>	<b>External:</b> 22, 24, 26
<b>External Face:</b>	Polyester Std. G60, Kynar G90
<b>Internal face:</b>	White Vinyl
<b>Std. Coating:</b>	USDA Approved
<b>Orientation:</b>	Vertical - Horizontal

Other paint systems available upon demand. For trims and accessories, ask your sales rep or contact Isocindu for more information and availability.

### Features

Monolayer wall panel with rigid polyurethane foam insulation. Outer face made of profiled steel with different architectural finishes. Inner face made of a unique white vinyl material. **Available in standard colors RAL 9010 and RAL 9002**

### Options

Isoparete Vinyl is an affordable panel with a vinyl interior that provides a better internal view, thermal insulation, and easy cleaning of the construction with the exterior architectural quality offered in striated, box, and piano profiled steel. It features hidden fastening system. Available with butyl seal placed in plant.

### Benefits

- Easy to clean
- Sanitary
- Mold and moisture resistant
- High thermal resistance

### Suitable for

-  **Industrial:** Warehouse, Distribution Centers, Livestock Plants
-  **Cold Chain:** Cold Chambers, Freezers
-  **Commercial:** Offices, Kitchens, Hospitals, Residential Sofits
-  **Specialized:** Airport hangers, Green Building, Food Processing

### Face Profiles

Striated and flat profiles, it's recommended to use 24 gauge or higher.

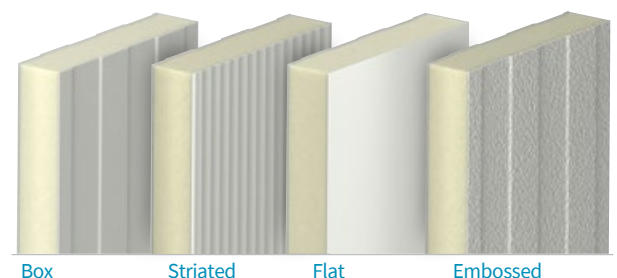

### Concealed Fastener

#### Panel Weight

		Exterior Face Steel Gauge		
		26	24	22
<b>16.3</b>	PSF	5.58	6.07	6.89
<b>20.5</b>	PSF	4.92	5.41	6.40
<b>24.6</b>	PSF	4.59	4.92	5.58
<b>28.7</b>	PSF	4.27	4.59	5.25
<b>32.8</b>	PSF	3.94	4.27	4.92

#### Dimensional Tolerance

<b>Length</b>	L ≤ 9' 10" ± 1/8" L > 9' 10" ± 3/8"	<b>Perpendicularity Deviation</b>	1/4"
<b>Working Length</b>	± 1/16"	<b>Misalignment of the internal metal surfaces</b>	± 1/8"
<b>Thickness</b>	D ≤ 4" ± 1 1/16" D > 4" ± 2 %	<b>Bottom Sheet Coupling</b>	F = 1 + 1/8"

L = working length, D = panel thickness, F = sheet coupling

#### Thermal Insulation

Thickness	1 1/4"	1 3/8"	2"	2 1/2"
Value	PIR R+ 75° F Mean Temp (95° to 55°) ASTM C518			
<b>U</b> (Btu/H ft² F)	0.08	0.08	0.06	0.05
<b>R</b> (H ft² F/Btu)	11.3	12.3	15.1	18.8
Value	PIR R+ 35° F Mean Temp (55° to 15°) ASTM C518			
<b>U</b> (Btu/H ft² F)	0.07	0.07	0.05	0.04
<b>R</b> (H ft² F/Btu)	12.4	13.8	16.8	20.8

#### Expansion Joint

**Profile Option 1: Standard Gap 1/8"**, recommended to select the expansion joint in dark colors (L < 75) to reduce thermal expansion.

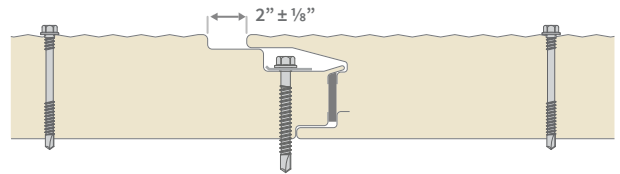

**Profile Option 2: No Gap Between**

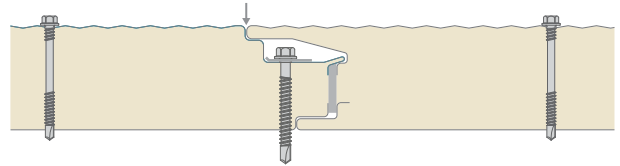

It's important to securely fasten monolayer wall panels to the structure using additional screws along the width of the panel. Contact your sales agent for more details about installation.

### Exposed Fastener



### Specifications

<b>Length:</b>	Maximum of 53'
<b>Width:</b>	★ 39 3/8" / 45 1/4"
<b>Thickness:</b>	1 1/8" 2" 2 1/2" 3" 4" 5" 6" 8"
<b>Foam Core:</b>	PUR, PIR, PIR R+, Leaf (Best R value) 2.62 - 2.49 LB/FT <sup>3</sup>
<b>Joint Type:</b>	Tongue and Groove - Exposed
<b>Gasket:</b>	Open Cell Gasket - Butyl available upon request
<b>Steel Gauge:</b>	<b>External:</b> 22, 24, 26 - <b>Internal:</b> 22, 24, 26, 28
<b>Coating:</b>	Polyester Std. G60, Kynar G90, Stainless Steel 314
<b>Std. Coating:</b>	USDA Approved
<b>Orientation:</b>	Vertical - Horizontal

Other paint systems available upon demand. For trims and accessories, ask your sales rep or contact Isocindu for more information and availability.

### Features

A double-steel sheet wall panel, insulated with rigid foam. The tongue-and-groove joint is completed by exposed fasteners and saddle clip. External face available in striated, box and flat profiles. The internal face is standard with the box profile (*contact us for other options*). Available in 45 1/4" width, perfect size for cold storage.





### Options

Isobox is a sandwich panel for coating used in walls of industrial buildings, and internal partitions, suitable for cooling chambers. Available with butyl seal placed in plant.

### Benefits

- Up to 8" thick
- Available in 45 1/4" width
- Gasket barrier to prevent vapor leaks
- High mechanical strength
- High thermal resistance for controlled temperatures

### Suitable for

-  **Industrial:** Warehouse, Factories, Distribution Centers
-  **Cold Chain:** Cold Chambers, Freezers, Mid Size Labs
-  **Commercial:** Office, Retail, Restaurants
-  **Architectural:** Schools, Museums, Government
-  **Specialized:** Airports, Green Building

### Face Profiles

Striated and flat profiles, it's recommended to use 24 gauge or higher.

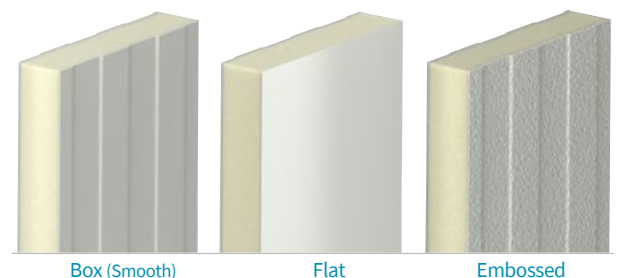

### Exposed Fastener

### Load Chart

Distance Between 2 Simple Supports							
PSF	16	20	24	28	32	36	40
Thickness	26/26 Ga - PIR with 10% Safety Factor - PSF Values						
1½"	8'-6"	7'-6"	6'-10"	6'-2"	5'-8"	5'-4"	5'-1"
2"	10'-2"	9'-0"	8'-2"	7'-6"	6'-10"	6'-4"	6'-1"
2½"	11'-5"	10'-5"	9'-6"	8'-8"	8'-1"	7'-6"	7'-1"
3"	13'-7"	12'-3"	11'-1"	10'-2"	9'-6"	9'	8'-4"
4"	16'-1"	14'-9"	13'-7"	12'-7"	11'-11"	11'-3"	10'-7"
5"	18'-8"	17'-10"	15'-7"	14'-7"	13'-7"	12'-11"	12'-3"
6"	20'-8"	18'-8"	17'-2"	15'-8"	15'-1"	15'-1"	13'-5"
8"	25'-5"	23'-3"	21'-1"	19'-8"	18'-10"	17'-8"	16'-6"

Distance Between Multiple Supports							
PSF	16	20	24	28	32	36	40
Thickness	26/26 Ga - PIR with 10% Safety Factor - PSF Values						
1½"	9'-6"	8'-6"	7'-6"	7'-6"	6'-6"	5'-2"	4'-9"
2"	11'-5"	10'-2"	9'-2"	8'-2"	7'-2"	6'-6"	5'-10"
2½"	13'-5"	11'-9"	10'-5"	9'-8"	8'-8"	7'-10"	7'-1"
3"	15'-7"	13'-9"	12'-1"	11'-1"	10'-2"	9'-4"	8'-8"
4"	17'-2"	15'-5"	13'-7"	12'-5"	11'-7"	11'-1"	10'-4"
5"	18'-8"	16'-1"	14'-7"	13'-5"	12'-3"	11'-7"	10'-11"
6"	24'-3"	20'-11"	18'-2"	16'-6"	15'-1"	13'-9"	13'-1"
8"	24'-7"	22'-5"	19'-4"	17'-4"	15'-7"	13'-11"	13'-5"

### Panel Weight

Steel Thickness	Panel Nominal Thickness (in)							
	1½"	2"	2½"	3"	4"	5"	6"	8"
26/26 PSF	2.07	2.14	2.24	2.33	2.52	2.70	2.89	3.27
24/26 PSF	2.44	2.51	2.61	2.70	2.85	3.04	3.26	3.64
24/24 PSF	2.78	2.85	2.94	3.04	3.22	3.41	3.60	3.97
22/26 PSF	2.72	2.70	2.88	2.98	3.16	3.35	3.54	3.91

### Dimensional Tolerance

Length	L ≤ 9' 10" ± 1/8" L > 9' 10" ± 3/8"	Perpendicularity Deviation	1/4"
Working Length	± 1/16"	Misalignment of the internal metal surfaces	± 1/8"
Thickness	D ≤ 4" ± 1 1/16" D > 4" ± 2 %	Bottom Sheet Coupling	F = 1 + 1/8"

L = working length, D = panel thickness, F = sheet coupling

### Thermal Insulation

Thickness	1½"	2"	2½"	3"	4"	5"	6"	8"
Value	PIR R+ 75° F Mean Temp (95° to 55°) ASTM C518							
U (Btu/H ft² F)	0.08	0.06	0.05	0.04	0.03	0.02	0.02	0.01
R (H ft² F/Btu)	12.3	15.1	18.8	22.6	30.1	37.7	44.9	60.4
Value	PIR R+ 35° F Mean Temp (55° to 15°) ASTM C518							
U (Btu/H ft² F)	0.07	0.05	0.04	0.04	0.03	0.02	0.02	0.01
R (H ft² F/Btu)	13.8	16.8	20.8	25.2	33.7	42.1	50.5	67.4

### Important Notes

"The load chart above does not apply to ceilings. Project-specific load calculation requirements must be determined by the design team and/or structural engineer.

- 1.- The results are considered without any fasteners (Fablock/clamping screws).
- 2.- The results were considered with a maximum deflection of L/180.
- 3.- The results do not take into account the thickness of the supports or the fastening method. The results exclude the temperature differential.
- 4.- For extendable load chart contact technical department



Isobox, striated and Flat, are FM (Factory Mutual) certified only in thicknesses from 1½" to 6", in standards 4880 and 4881.

### Joint Section

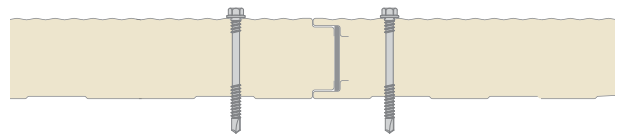
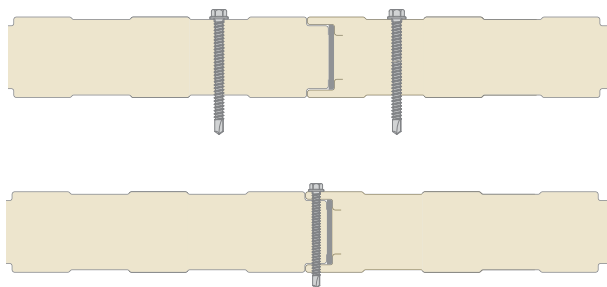

### TPO & PVC Steel Exposed Fastener

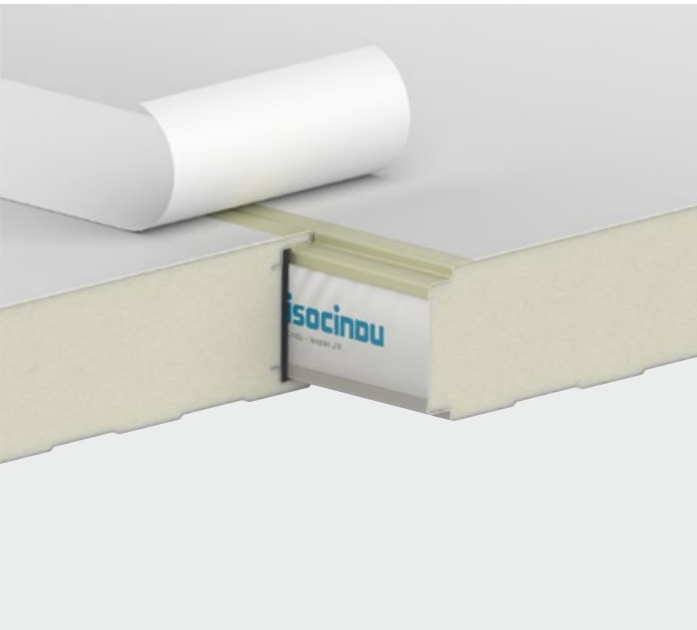

## Specifications

<b>Length:</b>	Maximum of 53'
<b>Width:</b>	★ 39 3/8"
<b>Thickness:</b>	1 1/2" 2" 2 1/2" 3" 4" 5" 6" 8"
<b>Foam Core:</b>	PUR, PIR, PIR R+, Leaf (Best R value) 2.62 - 2.49 LB/FT <sup>3</sup>
<b>Joint Type:</b>	Tongue and Groove - Exposed
<b>Gasket:</b>	Open Cell Gasket - Butyl available upon request
<b>Steel Gauge:</b>	Exterior: 22 - Interior: 22, 24, 26, 28
<b>External Face:</b>	PVC/TPO Coated Metal Base
<b>Internal Face:</b>	Pre-painted Coated Steel (ASTM A653)
<b>Std. Coating:</b>	USDA Approved
<b>Orientation:</b>	Vertical - Horizontal

Other paint systems available upon demand. For trims and accessories, ask your sales rep or contact Isocindu for more information and availability.

## Features

This system is our isobox wall panel with the external face in TPO or PVC, a single PLY membrane system.

The TPO is composed of a thermoplastic waterproofing membrane, characterized by the absence of plasticizers and halogens, giving resistance to aging, UV rays, and atmospheric agents making. The synthetic PVC-P, is a light gray top layer, highly resistant to atmospheric agents and UV rays.

## Options





Isoparete TPO / PVC is an affordable panel that provides a better internal view, thermal insulation, and easy cleaning, with functional quality. Available with butyl seal placed in plant.

## Benefits

**TPO:** Lightweight, UV-resistant, flexible, and cost-effective, ideal for energy efficiency and solar reflectivity requirements.

**PVC:** Strong, fire-retardant, chemically resistance and long lasting. Perfect for industrial, hygienic or safety applications

## Suitable for

-  **Industrial:** Warehouse, Factories, Distribution Centers
-  **Cold Chain:** Cold Chambers, Freezers, Cold Chain Facilities
-  **Commercial:** Offices, Malls, Convention Centers
-  **Architectural:** Schools, Government, Transport hubs
-  **Specialized:** Flat Roofs, Green Building, Data Centers

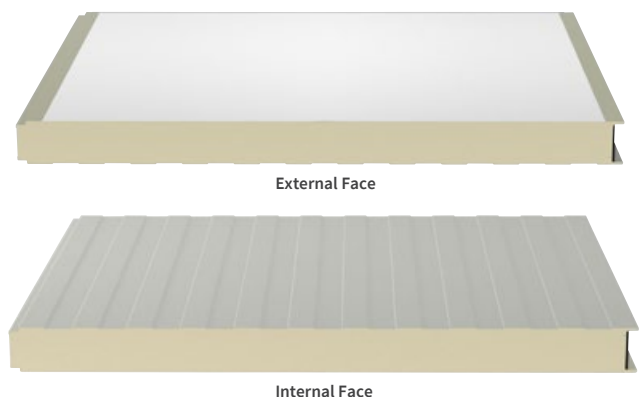

### TPO & PVC Steel Exposed Fastener

#### Panel Weight

Steel Thickness		Panel Nominal Thickness (in)							
		1½"	2"	2½"	3"	4"	5"	6"	8"
26/26	PSF	2.07	2.14	2.24	2.33	2.52	2.70	2.89	3.27
24/26	PSF	2.44	2.51	2.61	2.70	2.85	3.04	3.26	3.64
24/24	PSF	2.78	2.85	2.94	3.04	3.22	3.41	3.60	3.97
22/26	PSF	2.72	2.70	2.88	2.98	3.16	3.35	3.54	3.91

#### Thermal Insulation

Thickness	1½"	2"	2½"	3"	4"	5"	6"	8"
Value	PIR R+ 75° F Mean Temp (95° to 55°) ASTM C518							
U (Btu/H ft² F)	0.08	0.06	0.05	0.04	0.03	0.02	0.02	0.01
R (H ft² F/Btu)	12.3	15.1	18.8	22.6	30.1	37.7	44.9	60.4
Value	PIR R+ 35° F Mean Temp (55° to 15°) ASTM C518							
U (Btu/H ft² F)	0.07	0.05	0.04	0.04	0.03	0.02	0.02	0.01
R (H ft² F/Btu)	13.8	16.8	20.8	25.2	33.7	42.1	50.5	67.4

#### Load Chart

To obtain specific information about the panel's load capacity values, please contact an authorized Isocindu sales representative or technical specialist.

#### Dimensional Tolerance

Lenght	L ≤ 9' 10" ± 1/8" L > 9' 10" ± 3/8"	Perpendicularity Deviation	1/4"
Working Lenght	± 1/16"	Misalignment of the internal metal surfaces	± 1/8"
Thickness	D ≤ 4" ± 1 1/16" D > 4" ± 2 %	Bottom Sheet Coupling	F = 1 + 1/8"

L = working length, D = panel thickness, F = sheet coupling

#### Joint Section

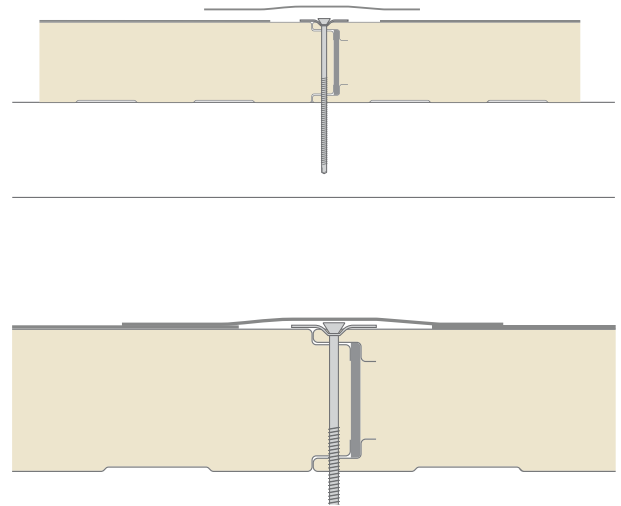

### Exposed Fastener

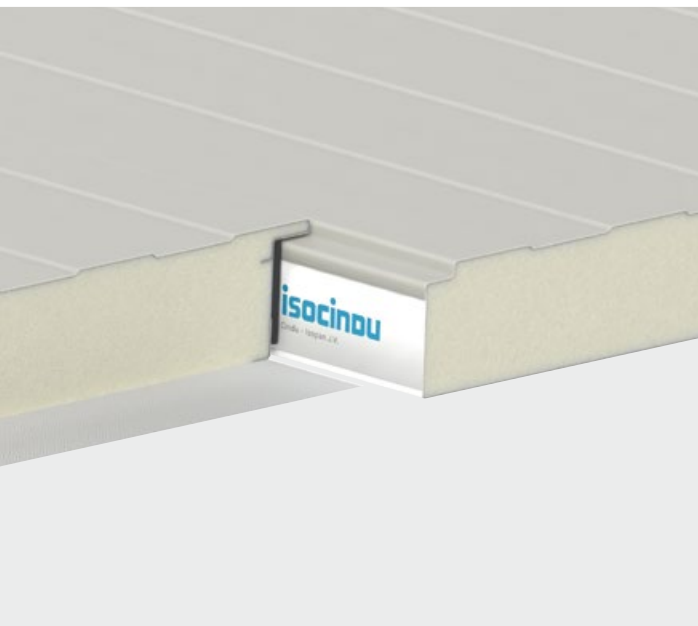

### Features

Monolayer wall panel with rigid polyurethane foam insulation. Outer face made of profiled steel with different architectural finishes. Inner face made of a unique white vinyl material. Available in 45¼" width, perfect size for cold storage. **Available in standard colors RAL 9010 and RAL 9002**

### Options

IsoBox Vinile is an affordable panel with a vinyl interior that provides a better internal view, thermal insulation, and easy cleaning of the construction with the exterior architectural quality offered in striated, box, and piano profiled steel. It features an exposed fastening system. Available with butyl seal placed in plant.

### Benefits

- Hygienic
- Washable
- Mold resistant
- High thermal resistance

### Specifications

<b>Lenght:</b>	Maximum length of 20'
<b>Width:</b>	★ 39 ¾" - 45¼"
<b>Thickness:</b>	1¼" 1⅝" 2" 2½"
<b>Foam Core:</b>	PUR, PIR, PIR R+, Leaf (Best R value) 2.62 - 2.49 LB/FT <sup>3</sup>
<b>Joint Type:</b>	Tongue and Groove - Exposed
<b>Gasket:</b>	Open Cell Gasket - <i>Butyl available upon request</i>
<b>Steel Gauge:</b>	<b>External:</b> 22, 24, 26
<b>External Face:</b>	Polyester Std. G60, Kynar G90
<b>Internal face:</b>	White Vinyl
<b>Std. Coating:</b>	USDA Approved
<b>Orientation:</b>	Vertical - Horizontal

Other paint systems available upon demand. For trims and accessories, ask your sales rep or contact Isocindu for more information and availability.

### Suitable for

- Industrial:** Warehouse, Distribution Centers, Livestock Plants
- Cold Chain:** Cold Chambers, Freezers
- Commercial:** Offices, Kitchens, Hospitals, Residential Sofits
- Specialized:** Airports, Green Building, Food Processing

### Face Profiles

Striated and flat profiles, it's recommended to use 24 gauge or higher.

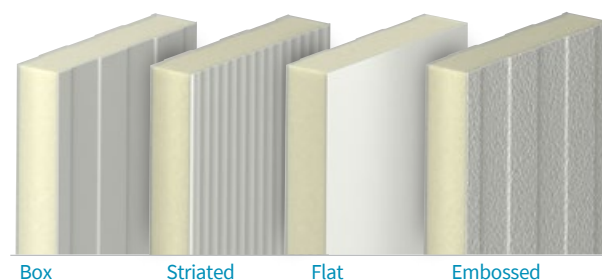

### Exposed Fastener

#### Panel Weight

		Exterior Face Steel Gauge		
		26	24	22
<b>16.3</b>	PSF	5.58	6.07	6.89
<b>20.5</b>	PSF	4.92	5.41	6.40
<b>24.6</b>	PSF	4.59	4.92	5.58
<b>28.7</b>	PSF	4.27	4.59	5.25
<b>32.8</b>	PSF	3.94	4.27	4.92

#### Dimensional Tolerance

<b>Length</b>	L ≤ 9' 10" ± 1/8" L > 9' 10" ± 3/8"	<b>Perpendicularity Deviation</b>	1/4"
<b>Working Length</b>	± 1/16"	<b>Misalignment of the internal metal surfaces</b>	± 1/8"
<b>Thickness</b>	D ≤ 4" ± 1 1/16" D > 4" ± 2 %	<b>Bottom Sheet Coupling</b>	F = 1 + 1/8"

L = working length, D = panel thickness, F = sheet coupling

#### Thermal Insulation

Thickness	1 1/4"	1 5/8"	2"	2 1/2"
<b>Value</b>	PIR R+ 75° F Mean Temp (95° to 55°) ASTM C518			
<b>U</b> (Btu/H ft² F)	0.08	0.08	0.06	0.05
<b>R</b> (H ft² F/Btu)	11.3	12.3	15.1	18.8
<b>Value</b>	PIR R+ 35° F Mean Temp (55° to 15°) ASTM C518			
<b>U</b> (Btu/H ft² F)	0.07	0.07	0.05	0.04
<b>R</b> (H ft² F/Btu)	12.4	13.8	16.8	20.8

#### Joint Section

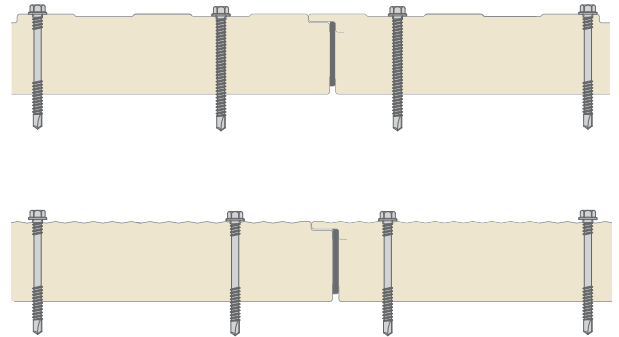

It's important to securely fasten monolayer wall panels to the structure using additional screws along the width of the panel. Contact your sales agent for more details about installation.

### Concealed Fastener

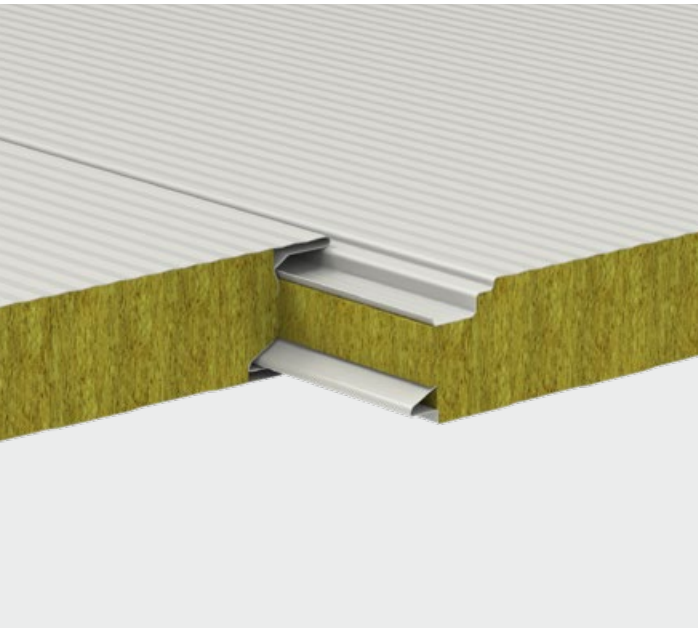

### Features

Self-supporting all panel with double steel sheet, mineral wool core and striated external face. Hidden fastening joint with pass-through screw.

### Options

Isofire Wall is a insulated metal panel used in industrial and commercial building walls, the striated profile external face offers an architectural finish. The joint is characterized by a hidden fastening system. The mineral wool insulation makes it an excellent fire resistant.

### Benefits

- Non combustible
- Hidden fastening for aesthetic appearance
- Acoustic insulation
- Versatility to be installed vertically or horizontally
- Reaction to fire according to A2-s1-d0 class

 Designed to provide fire protection from 1 to 3 hours for industrial and commercial buildings





### Specifications

<b>Length:</b>	Maximum recommended 40'
<b>Width:</b>	★ 39 3/8" - 100 cm
<b>Thickness:</b>	50*, 60*, 80*, 100, 120, 150, 170, 200 (mm)
<b>Foam Core:</b>	Mineral Wool - 100 kg/m <sup>3</sup>
<b>Joint Type:</b>	Tongue and Groove - Hidden
<b>Gasket:</b>	Open Cell Gasket
<b>Steel Gauge:</b>	<b>External:</b> 0,5 - 0,8 mm - <b>Internal:</b> 0,5 - 0,8 mm
<b>Coating:</b>	Polyester Std. G60
<b>Orientation:</b>	Vertical - Horizontal

Other paint systems available upon demand. For trims and accessories, ask your sales rep or contact Isocindu for more information and availability.

(\*) These thicknesses are the minimum production requirement.

### Suitable for

-  **Industrial:** Warehouse, Factories, Manufacturing Facilities
-  **Cold Chain:** Cold Chambers, Food Processing
-  **Commercial:** Offices, Malls, Convention Centers
-  **Architectural:** Schools, Atriums, Halls
-  **Specialized:** Green Building, Data Centers, Grain Sheds

### Face Profiles

Striated and flat profiles, it's recommended to use 24 gauge or higher.

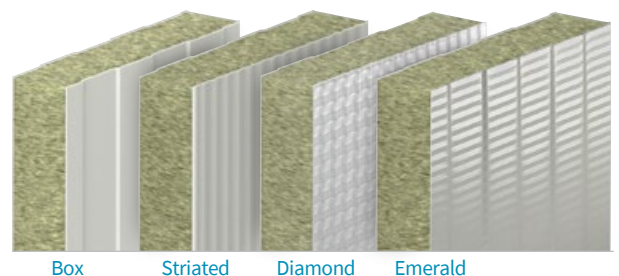

### Concealed Fastener

#### Load Chart

Kg/m <sup>2</sup>	Distance Between 2 Simple Supports							
	Panel nominal tickness (mm)							
	50	60	80	100	120	150	170	200
Sheets 0,5mm / 0,5mm - Support 120 mm								
50	440	480	540	610	670	755	805	890
60	390	430	495	570	625	700	750	825
80	310	355	425	500	550	615	650	715
100	250	295	365	440	490	550	580	630
120	210	250	315	385	435	495	525	565
140	180	210	275	340	390	440	475	510
160	160	185	245	300	350	400	435	465
180	145	165	220	270	320	360	395	425
200	130	150	205	250	295	330	360	390
Sheets 0,6mm / 0,6mm - Support 120 mm								
50	490	520	600	675	720	800	860	935
60	425	470	475	635	685	755	810	870
80	335	380	410	550	605	670	720	760
100	265	310	365	460	525	585	630	665
120	235	270	355	410	470	525	560	595
140	200	230	325	360	415	470	505	535
160	175	210	275	315	370	415	445	480
180	160	190	255	275	335	375	405	430
200	140	165	235	255	305	335	365	400

Kg/m <sup>2</sup>	Distance Between Multiple Supports								
	Panel nominal tickness (mm)								
	50	60	80	100	120	150	170	200	
Sheets 0,5mm / 0,5mm - Support 120 mm									
50	390	420	460	500	540	580	630	670	
60	345	380	415	450	490	520	550	585	
80	270	310	345	370	400	425	450	485	
100	210	250	285	310	335	355	375	405	
120	180	205	240	265	285	305	325	350	
140	155	175	210	230	250	265	280	300	
160	130	155	185	205	220	230	245	265	
180	120	135	165	180	195	205	220	240	
200	110	120	150	165	180	190	205	220	
Sheets 0,6mm / 0,6mm - Support 120 mm									
50	430	460	500	540	580	610	650	680	
60	375	415	455	490	530	560	590	615	
80	290	330	375	405	440	465	495	515	
100	220	260	300	330	360	380	405	425	
120	190	220	250	280	305	325	345	365	
140	160	190	220	240	265	280	300	320	
160	140	165	195	215	230	245	265	280	
180	130	150	175	195	210	225	240	255	
200	115	135	160	180	195	210	225	240	

#### Thermal Insulation

According to standard EN 14509 (no.8)

U	50	60	80	100	120	150	170	200
W/m <sup>2</sup> ·K	0.75	0.63	0.49	0.39	0.33	0.27	0.24	0.17
Btu/hft <sup>2</sup> °F	0.13	0.11	0.08	0.06	0.05	0.04	0.04	0.03
K	50	60	80	100	120	150	170	200
W/m <sup>2</sup> ·K	0.75	0.64	0.50	0.40	0.33	0.27	0.24	0.20
Btu/hft <sup>2</sup> °F	0.15	0.13	0.10	0.08	0.06	0.05	0.05	0.04

#### Panel Weight

Steel thickness	50	60	80	100	120	150	170	200
	Values in kg/m <sup>2</sup>							
0,5 / 0,5	13.2	14.2	16.2	18.2	20.2	23.2	25.2	28.2
0,6 / 0,6	14.9	15.9	17.9	19.9	21.9	24.9	26.9	29.9

#### Joint Section

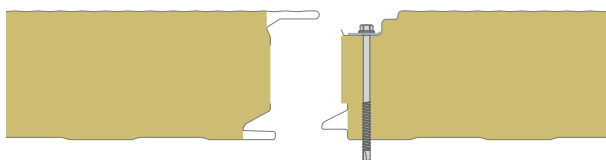

#### Dimensional Tolerance

L = Length, D = Thickness, F = Support

Lenght	L ≤ 3 m ± 5 mm L > 3 m ± 10 mm	Perpendicularity Deviation	6 mm
Working Lenght	± 2 mm	Misalignment of the internal metal surfaces	± 3 mm
Thickness	D ≤ 100 mm ± 2mm D > 100 mm ± 2%	Bottom Sheet Coupling	F = 0 +3 mm

L = working length, D = panel thickness, F = sheet coupling

#### Fire Reaction and Resistance

See page 14 & 15



Isofire wall is FM (Factory Mutual) certified in standards 4880 and 4881.

For equivalent certifications and testings contact your sales agent

### Exposed Fastening

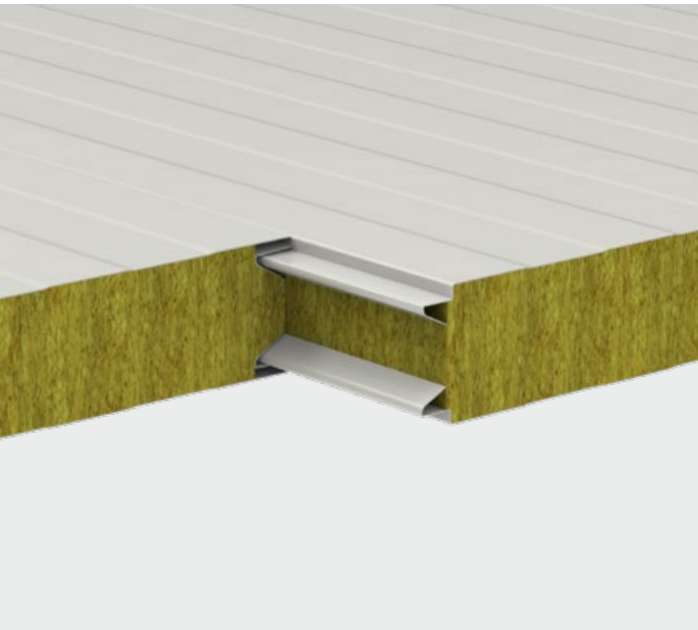

### Features

Self-supporting wall panel with double steel sheet and mineral wool core. The tongue-and-groove joint is made by exposed through screws and fasteners along the supports.

### Options

Isofire Wall is a insulated metal panel used in industrial and commercial building walls. It has tongue-and-groove joints and visible fastening. The mineral wool insulation makes it an excellent fire resistant.

### Benefits

- Non combustible
- Fire Resistant
- Acoustic insulation
- Versatility to be installed vertically or horizontally
- Reaction to fire according to A2-s1-d0 class

 Designed to provide fire protection from 1 to 3 hours for industrial and commercial buildings





### Specifications

<b>Length:</b>	Maximum recommended 40'
<b>Width:</b>	★ 39 3/8" - 100 cm
<b>Thickness:</b>	50*, 60*, 80*, 100, 120, 150, 170, 200 (mm)
<b>Foam Core:</b>	Mineral Wool - 100 kg/m <sup>3</sup>
<b>Joint Type:</b>	Tongue and Groove - Exposed
<b>Gasket:</b>	Open Cell Gasket
<b>Steel Gauge:</b>	<b>External:</b> 0,5 - 0,8 mm - <b>Internal:</b> 0,5 - 0,8 mm
<b>Coating:</b>	Polyester Std. G60
<b>Orientation:</b>	Vertical - Horizontal

Other paint systems available upon demand. For trims and accessories, ask your sales rep or contact Isocindu for more information and availability.

(\*) These thicknesses are the minimum production requirement.

### Suitable for

-  **Industrial:** Warehouse, Factories, Distribution Centers
-  **Cold Chain:** Cold Chambers, Food Processing
-  **Commercial:** Offices, Malls, Convention Centers
-  **Architectural:** Schools, Halls, Government
-  **Specialized:** Green Building, Data Centers, Grain Sheds

### Face Profiles

Striated and flat profiles, it's recommended to use 24 gauge or higher.

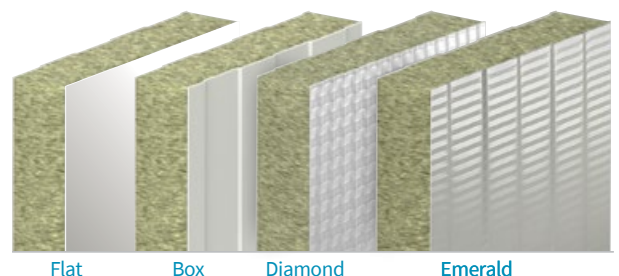

### Exposed Fastening

#### Load Chart

Kg/m <sup>2</sup>	Distance Between 2 Simple Supports								
	Panel nominal tickness (mm)								
	50	60	80	100	120	150	170	200	240
<b>(Thickness less than 100mm) Sheets 0,5mm / 0,5mm - Support 120 mm</b>									
50	440	480	540	610	670	755	805	890	960
60	390	430	495	570	625	700	750	825	895
80	310	355	425	500	550	615	650	715	770
100	250	295	365	440	490	550	580	630	680
120	210	250	315	385	435	495	525	565	610
140	180	210	275	340	390	440	475	510	550
160	160	185	245	300	350	400	435	465	500
180	145	165	220	270	320	360	395	425	450
200	130	150	205	250	295	330	360	390	415
<b>Sheets 0,6mm / 0,6mm - Support 120 mm</b>									
50	490	520	600	675	720	800	860	935	980
60	425	470	545	635	685	755	810	870	920
80	335	380	465	550	605	670	720	760	820
100	265	310	385	460	525	585	630	665	730
120	235	270	330	410	470	525	560	595	645
140	200	230	290	360	415	470	505	535	570
160	175	210	260	315	370	415	445	480	520
180	160	190	230	275	335	375	405	430	470
200	140	165	210	255	305	335	365	400	430

Kg/m <sup>2</sup>	Distance Between Multiple Supports								
	Panel nominal tickness (mm)								
	50	60	80	100	120	150	170	200	200
<b>(Thickness less than 100mm) Sheets 0,5mm / 0,5mm - Support 120 mm</b>									
50	390	420	460	500	540	580	630	670	700
60	345	380	415	450	490	520	550	585	620
80	270	310	345	370	400	425	450	485	520
100	210	250	285	310	335	355	375	405	430
120	180	205	240	265	285	305	325	350	370
140	155	175	210	230	250	265	280	300	320
160	130	155	185	205	220	230	245	265	290
180	120	135	165	180	195	205	220	240	260
200	110	120	150	165	180	190	205	220	240
<b>Sheets 0,6mm / 0,6mm - Support 120 mm</b>									
50	430	460	500	540	580	610	650	680	710
60	375	415	455	490	530	560	590	615	640
80	290	330	375	405	440	465	495	515	545
100	220	260	300	330	360	380	405	425	455
120	190	220	250	280	305	325	345	365	390
140	160	190	220	240	265	280	300	320	340
160	140	165	195	215	230	245	265	280	300
180	130	150	175	195	210	225	240	255	275
200	115	135	160	180	195	210	225	240	260

#### Thermal Insulation According to standard EN 14509 (no.8)

U	50	60	80	100	120	150	170	200
W/m <sup>2</sup> ·K	0.86	0.72	0.52	0.41	0.35	0.28	0.24	0.20
Btu/hft <sup>2</sup> °F	0.15	0.12	0.09	0.07	0.06	0.05	0.04	0.03
K	50	60	80	100	120	150	170	200
W/m <sup>2</sup> ·K	0.75	0.64	0.50	0.40	0.33	0.27	0.24	0.20
Btu/hft <sup>2</sup> °F	0.15	0.13	0.10	0.08	0.06	0.05	0.05	0.04

#### Panel Weight

Steel thickness	50	60	80	100	120	150	170	200	240
	Values in kg/m <sup>2</sup>								
0.5 / 0.5	13.2	14.2	16.2	18.2	20.2	23.2	25.2	28.2	32.2
0.6 / 0.6	14.9	15.9	17.9	19.9	21.9	24.9	26.9	28.9	32.9

#### Joint Section



#### Dimensional Tolerance

Lenght	L ≤ 3 m ± 5 mm L > 3 m ± 10 mm	Perpendicularity Deviation	6 mm
Working Lenght	± 2 mm	Misalignment of the internal metal surfaces	± 3 mm
Thickness	D ≤ 100 mm ± 2mm D > 100 mm ± 2%	Bottom Sheet Coupling	F = 0 +3 mm

L = working length, D = panel thickness, F = sheet coupling

#### Fire Reaction and Resistance

See page 14 & 15



Isofire wall is FM (Factory Mutual) certified in standards 4880 and 4881.

For equivalent certifications and testings contact your sales agent

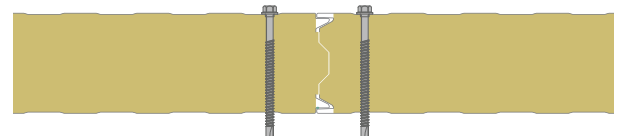

### Exposed Fastening

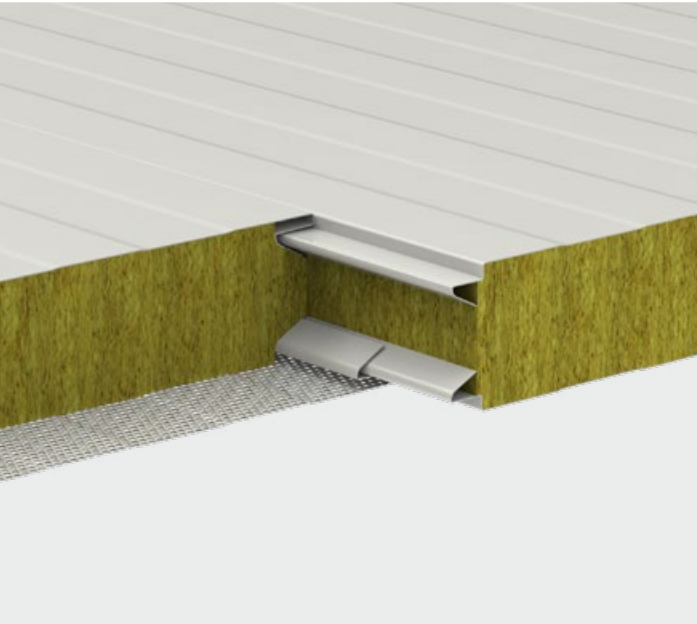

### Features

Self-supporting panel of double steel sheet, with mineral wool core. The tongue-and-groove joint is concealed by through-bolts and washers along the supports. The internal micro-perforated steel sheet increases the acoustic insulation and absorption of the panel.

### Options

Isofire wall fono has an internal support formed by a micro-perforated sheet, with the main function of increasing the sound-absorbing performance of the panel, reducing decibel levels improving interior comfort.

### Benefits

- Non Combustible
- Acoustic Insulation and absorption
- Fire reaction according to class A2-s1-d0
- Superior acoustic performance

 Designed to provide fire protection from 1 to 3 hours for industrial and commercial buildings

### Specifications

**Length:** Maximum recommended 40'

**Width:** ★ 39 3/4" - 100 cm

**Thickness:** 50\*, 60\*, 80\*, 100, 120, 150 (mm)

**Foam Core:** Mineral Wool - 100 kg/m<sup>3</sup>

**Joint Type:** Tongue and Groove - Exposed

**Gasket:** Open Cell Gasket

**Steel Gauge:** **External:** 0,5 - 0,8 mm - **Internal:** 0,6 mm

**External Face:** Polyester Std. G60

**Internal face:** Polyester and Micro-Perforated Steel

**Orientation:** Vertical - Horizontal

Other paint systems available upon demand. For trims and accessories, ask your sales rep or contact Isocindu for more information and availability.

(\*) These thicknesses are the minimum production requirement.

### Suitable for

 **Industrial:** Warehouse, Factories

 **Cold Chain:** Cold Chambers, Food Processing

 **Commercial:** Offices, Convention Centers, Record Studios

 **Architectural:** Schools, Theaters, Halls, Atriums

 **Specialized:** Healthcare, Green Building, Data Centers

### Face Profiles

Striated and flat profiles, it's recommended to use 24 gauge or higher.

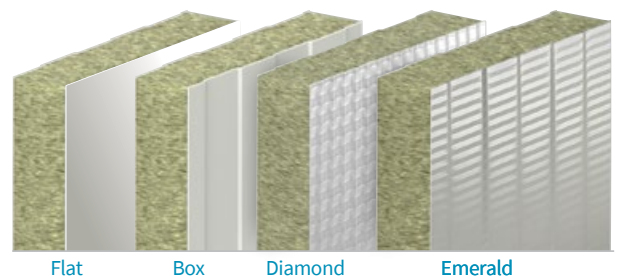

### Exposed Fastening

#### Load Chart

Kg/m <sup>2</sup>	Distance Between 2 Simple Supports					
	Panel nominal tickness (mm)					
	50	60	80	100	120	150
Sheets 0,5mm / 0,5mm - Support 120 mm						
50	370	400	450	510	560	635
60	325	360	415	475	525	585
80	260	295	355	420	460	515
100	210	245	305	370	410	460
120	175	210	265	320	365	415
140	150	175	230	285	325	370
160	130	155	205	250	290	335
180	120	135	185	225	265	300
200	105	125	170	210	245	275
Sheets 0,6mm / 0,6mm - Support 120 mm						
50	410	435	505	565	605	670
60	355	395	455	535	575	635
80	280	320	390	460	505	560
100	220	260	320	385	440	490
120	195	225	275	345	395	440
140	165	190	240	300	345	395
160	145	175	215	265	310	345
180	130	160	190	230	280	315
200	115	135	175	210	255	280

Kg/m <sup>2</sup>	Distance Between Multiple Supports					
	Panel nominal tickness (mm)					
	50	60	80	100	120	150
Sheets 0,5mm / 0,5mm - Support 120 mm						
50	325	350	385	420	455	485
60	290	320	345	375	410	435
80	225	260	290	310	335	355
100	175	210	240	260	280	295
120	150	170	200	220	240	255
140	130	145	175	190	210	220
160	105	130	155	170	185	190
180	100	110	135	150	160	170
200	90	100	125	135	150	160
Sheets 0,6mm / 0,6mm - Support 120 mm						
50	360	385	420	455	485	510
60	315	345	380	410	445	470
80	240	275	315	340	370	390
100	185	215	250	275	300	320
120	160	185	210	235	255	270
140	130	160	185	200	220	235
160	115	135	160	180	190	205
180	105	125	145	160	175	185
200	95	110	130	150	160	175

#### Thermal Insulation

According to standard EN 14509 (no.8)

U	50	60	80	100	120	150
W/m <sup>2</sup> -K	0.75	0.63	0.49	0.39	0.33	0.27
Btu/hft <sup>2</sup> °F	0.13	0.11	0.08	0.06	0.05	0.04
K	50	60	80	100	120	150
W/m <sup>2</sup> -K	0.75	0.64	0.50	0.40	0.33	0.27
Btu/hft <sup>2</sup> °F	0.15	0.13	0.10	0.08	0.06	0.05

#### Panel Weight

	50	60	80	100	120	150
Steel thickness	Values in kg/m <sup>2</sup>					
0.5 / 0.5	12.6	13.6	15.6	17.6	19.6	22.6
0.6 / 0.6	13.5	14.5	16.5	18.5	20.5	23.5

#### Joint Section

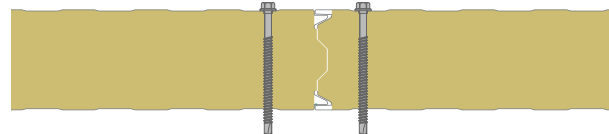

#### Dimensional Tolerance

Length	L ≤ 3 m ± 5 mm	Perpendicularity Deviation	6 mm
	L > 3 m ± 10 mm		
Working Length	± 2 mm	Misalignment of the internal metal surfaces	± 3 mm
Thickness	D ≤ 100 mm ± 2mm	Bottom Sheet Coupling	F = 0 +3 mm
	D > 100 mm ± 2%		

L = working length, D = panel thickness, F = sheet coupling

#### Fire and Acoustic Performance

See page 14 & 15





# Roof Panel

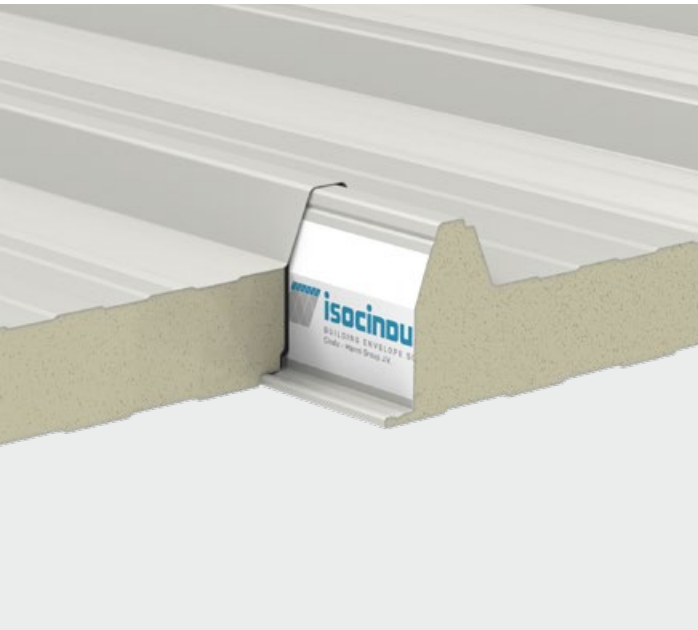

### Specifications

<b>Length:</b>	Maximum of 53'
<b>Width:</b>	★ 39 3/8"
<b>Thickness:</b>	1" 1 1/2" 2" 2 1/2" 3" 4" 5" 6" 8"
<b>Foam Core:</b>	PUR, PIR, PIR R+, Leaf (Best R value) 2.62 - 2.49 LB/FT <sup>3</sup>
<b>Joint Type:</b>	Tongue and Groove - Exposed
<b>Gasket:</b>	Open Cell Gasket - Butyl available upon request
<b>Steel Gauge:</b>	<b>External:</b> 22, 24, 26 - <b>Internal:</b> 22, 24, 26, 28
<b>Coating:</b>	Polyester Std. G60, Kynar G90
<b>Std. Coating:</b>	USDA Approved
<b>Orientation:</b>	Roof and wall
<b>Overlapping:</b>	Available

Other paint systems available upon demand. For trims and accessories, ask your sales rep or contact Isocindu for more information and availability.

### Features

A double-steel sheet roof panel, insulated with rigid foam. This design caters to 2% min slope roofs. External face with 4 trapezoidal rows to enhance static and dynamic forces. Exposed fastening system that includes saddle clips and cap ribs for concealed fastening and weather tightness. Applicable with several roofing sub-structures.





### Options

Especially suited for use in industrial, warehouses, zootechnical, and residential construction. Versatility, load resistance and easy installation make Isocop a reliable solution, from new construction to roof refurbishing. Available with butyl seal placed in plant.

### Benefits

- Rust resistance
- High mechanical strength
- Hygienic and easy wash material
- Mold and humidity resistance
- Gasket barrier to prevent vapor leaks

### Suitable for

-  **Industrial:** Warehouse, Factories, Distribution Centers
-  **Cold Chain:** Cold Chambers, Food Processing
-  **Commercial:** Office, Retail, Convention Centers
-  **Architectural:** Schools, Museums, Government
-  **Specialized:** Airports, Green Building, Grain Sheds

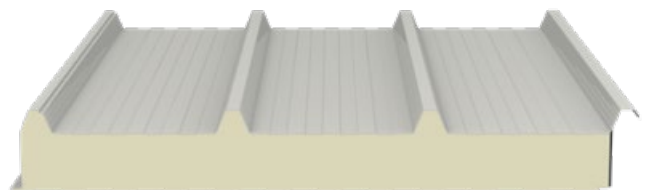

### Load Chart

Distance Between 2 Simple Supports						
PSF	16	20	30	40	51	
Thickness	26/26 Ga - PIR with 10% Safety Factor - PSF Values					
1"	9'-2"	8'-1"	6'-1"	4'-11"	3'-9"	
1½"	10'-5"	9'-4"	7'-6"	6'-1"	4'-11"	
2"	12'-1"	10'-9"	8'-8"	7'-1"	5'-10"	
2½"	13'-5"	12'-1"	9'-10"	8'-4"	6'-8"	
3"	16'-4"	14'-7"	11'-9"	9'-8"	8'-4"	
4"	18'-6"	16'-2"	13'-5"	11'-3"	9'-10"	
5"	19'-6"	17'-4"	14'-7"	12'-7"	10'-11"	
6"	20'-2"	18'-1"	15'-5"	13'-7"	11'-9"	
8"	20'-9"	18'-8"	16'-2"	14'-7"	12'-7"	

Distance Between Multiple Supports						
PSF	16	20	30	40	51	
Thickness	26/26 Ga - PIR with 10% Safety Factor - PSF Values					
1"	10'	10'-2"	6'-8"	5'-1"	3'-11"	
1½"	11'-3"	10'-2"	8'-4"	6'-8"	5'-4"	
2"	12'-11"	11'-9"	9'-10"	8'-1"	6'-6"	
2½"	13'-7"	12'-7"	10'-5"	8'-8"	7'-6"	
3"	17'-1"	15'-3"	12'-11"	10'-7"	9'-4"	
4"	19'-1"	17'-2"	14'-7"	12'-5"	10'-9"	
5"	20'-2"	18'-4"	15'-8"	13'-7"	11'-11"	
6"	20'-9"	19'-4"	16'-6"	14'-3"	12'-9"	
8"	21'-5"	20'	17'-2"	14'-11"	13'-7"	

### Panel Weight

Steel thickness	Panel Nominal Thickness (in)							
	1½"	2"	2½"	3"	4"	5"	6"	8"
26/26 PSF	2.05	2.14	2.24	2.33	2.52	2.70	2.89	3.27
24/26 PSF	2.42	2.51	2.61	2.70	2.85	3.04	3.26	3.64
24/24 PSF	2.75	2.85	2.94	3.04	3.22	3.41	3.60	3.97
22/26 PSF	2.70	2.70	2.88	2.98	3.16	3.35	3.54	3.91

### Dimensional Tolerance

<b>Length</b>	L ≤ 9' 10" ± 1/8" L > 9' 10" ± 3/8"	<b>Perpendicularity Deviation</b>	1/4"
<b>Working Length</b>	± 1/16"	<b>Misalignment of the internal metal surfaces</b>	± 1/8"
<b>Thickness</b>	D ≤ 4" ± 1 1/16" D > 4" ± 2 %	<b>Bottom Sheet Coupling</b>	F = 1 + 1/8"

L = working length, D = panel thickness, F = sheet coupling

### Important Notes

- 1.- The results are considered without any fasteners (Fablock/clamping screws).
- 2.- The results were considered with a maximum deflection of L/180.
- 3.- The results do not take into account the thickness of the supports or the fastening method. The results exclude the temperature differential.



Isocop 4 is FM (Factory Mutual) certified only in thicknesses from 1½" to 6", in standard 4471



Isocop evaluation apply from 2" to 8" with PIR foam in Division: 07 00 00 - Thermal and moisture protection, and Section: 07 40 00 - Roofing and siding panels.

### Thermal Insulation

Thickness	1"	1½"	2"	2½"	3"	4"	5"	6"	8"
Value	PIRR+ 75° F Mean Temp (95° to 55°) ASTM C518								
U (Btu/H ft² F)	0.13	0.08	0.06	0.05	0.04	0.03	0.02	0.02	0.01
R (H ft² F/Btu)	7.5	11.3	15.1	18.8	22.6	30.1	37.7	44.9	60.4
Value	PIRR+ 35° F Mean Temp (55° to 15°) ASTM C518								
U (Btu/H ft² F)	0.12	0.07	0.05	0.04	0.04	0.03	0.02	0.02	0.01
R (H ft² F/Btu)	8.4	12.4	16.8	20.8	25.2	33.7	42.1	50.5	67.4

### Joint Section - Roof Clip

It's mandatory to use Isocindu's saddle fastening

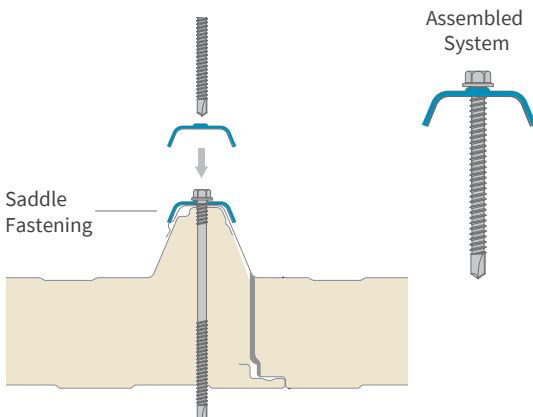

### Joint Section - Cap Rib

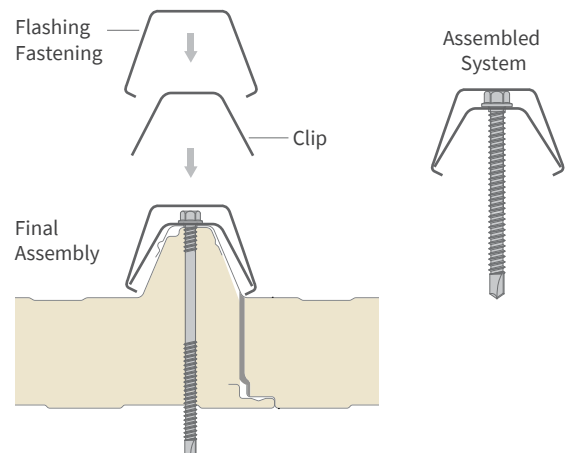



### Features

**Isoleck PVC Steel:** Single-layer synthetic PVC-P coating, with light gray top layer highly resistant to atmospheric agents and UV rays. The bottom layer is highly resistant to punctures and root attack.

**Isoleck TPO Steel:** Synthetic coating of TPO, a thermoplastic waterproofing membrane, optimal for commercial and industrial roofs with low slopes. The TPO membrane is characterized by the absence of plasticizers and halogens.

### Benefits

- Free of plasticizers and halogens
- Resistance to atmospheric agents and UV rays.
- High mechanical resistance
- High resistance to water & moderate chemical abrasion
- Resistant to static and dynamic loads





★ **Engineered to meet the most rigorous standards, this panel is the perfect choice for flat roof applications.**

### Specifications

<b>Length:</b>	Maximum of 53'
<b>Width:</b>	★ 39 3/8"
<b>Thickness:</b>	2" 2 1/2" 3" 4" 5" 6" 8"
<b>Foam Core:</b>	PUR, PIR, PIR R+, Leaf ( <b>Best R value</b> ) 2.62 - 2.49 LB/FT <sup>3</sup>
<b>Joint Type:</b>	Tongue and Groove - Hidden
<b>Gasket:</b>	Open Cell Gasket - <i>Butyl available upon request</i>
<b>Steel Gauge:</b>	Interior: 22, 24, 26
<b>External Face:</b>	Synthetic PVC or TPO
<b>Internal Face:</b>	Pre-painted Coated Steel (ASTM A653)
<b>Std. Coating:</b>	USDA Approved
<b>Orientation:</b>	Vertical - Horizontal

Other paint systems available upon demand. For trims and accessories, ask your sales rep or contact Isocindu for more information and availability.

### Suitable for

-  **Industrial:** Warehouse, Factories, Distribution Centers
-  **Cold Chain:** Cold Chambers, Freezers, Cold Chain Facilities
-  **Commercial:** Offices, Malls, Convention Centers
-  **Architectural:** Schools, Government, Transport hubs
-  **Specialized:** Flat Roofs, Green Building, Data Centers



### Load Chart

Distance Between 2 Supports						
PSF	20	24	30	40	51	61
Thickness	22/22 Ga - PIR with 10% Safety Factor - PSF Values					
2"	12'-7"	12'	12'-5"	9'-2"	7'-8"	6'-10"
2½"	13'-7"	12'-9"	11'-9"	9'-6"	9'	7'-10"
3"	15'-8"	14'-9"	13'-7"	11'-11"	10'	8'-10"
4"	18'-2"	16'-10"	15'-5"	13'-9"	11'-11"	10'
5"	19'-4"	18'-2"	16'-2"	14'-5"	13'-9"	10'-9"
6"	20'-11"	19'-7"	17'-6"	14'-7"	13'-7"	11'-5"
8"	22'-7"	20'-8"	19'-4"	15'-8"	16'-1"	13'-5"

Distance Between Multiple Supports						
PSF	20	24	30	40	51	61
Thickness	22/22 Ga - PIR with 10% Safety Factor - PSF Values					
2"	13'-9"	13'-3"	12'-3"	10'-4"	8'-10"	8'-1"
2½"	14'-9"	13'-11"	12'-11"	10'-7"	10'-2"	9'
3"	16'-10"	16'-2"	14'-9"	13'-1"	11'-1"	10'
4"	19'-4"	18'-1"	16'-6"	14'-11"	13'-1"	11'-1"
5"	20'-4"	19'-2"	17'	14'-9"	14'-11"	11'-11"
6"	21'-3"	20'-4"	18'-4"	16'-1"	14'-9"	12'-7"
8"	23'-3"	21'-7"	20'-9"	18'-2"	17'-10"	13'-7"

- 1.- The results are considered without any fasteners (Fablock/clamping screws).
- 2.- The results were considered with a maximum deflection of L/180.
- 3.- The results do not take into account the thickness of the supports or the fastening method. The results exclude the temperature differential.

### Thermal Insulation

Thickness	2"	2½"	3"	4"	5"	6"	8"
Value	PIR R+ 75° F Mean Temp (95° to 55°) ASTM C518						
U (Btu/H ft² F)	0.06	0.05	0.04	0.03	0.02	0.02	0.01
R (H ft² F/Btu)	15.1	18.8	22.6	30.1	37.7	44.9	60.4
Value	PIR R+ 35° F Mean Temp (55° to 15°) ASTM C518						
U (Btu/H ft² F)	0.05	0.04	0.04	0.03	0.02	0.02	0.01
R (H ft² F/Btu)	16.8	20.8	25.2	33.7	42.1	50.5	67.4

### Joint Section

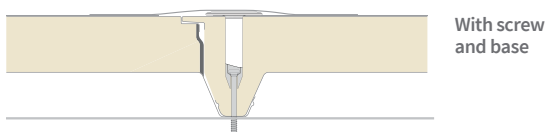
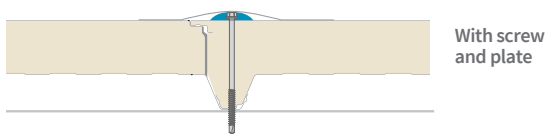

### Panel Weight

Steel thickness	Panel Nominal Thickness (in)						
	2"	2½"	3"	4"	5"	6"	8"
26/26 PSF	2.14	2.24	2.33	2.52	2.70	2.89	3.27
24/26 PSF	2.51	2.61	2.70	2.85	3.04	3.26	3.64
24/24 PSF	2.85	2.94	3.04	3.22	3.41	3.60	3.97
22/26 PSF	2.70	2.88	2.98	3.16	3.35	3.54	3.91

### Dimensional Tolerance

Lenght	L ≤ 9' 10" ± 1/8" L > 9' 10" ± 3/8"	Perpendicularity Deviation	1/4"
Working Lenght	± 1/16"	Misalignment of the internal metal surfaces	± 1/8"
Thickness	D ≤ 4" ± 1 1/16" D > 4" ± 2 %	Bottom Sheet Coupling	F = 1 + 1/8"

L = working length, D = panel thickness, F = sheet coupling

### Monolayer

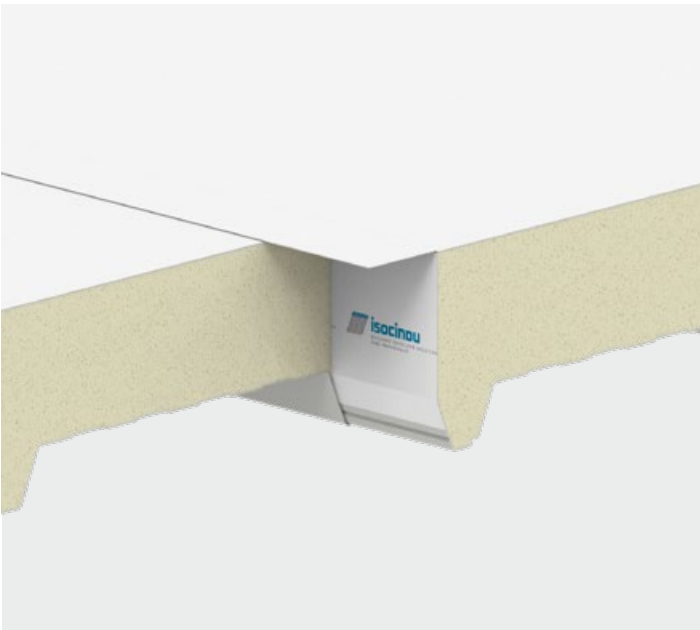

### Specifications

<b>Length:</b>	Maximum of 53'
<b>Width:</b>	★ 39 3/8"
<b>Thickness:</b>	1" 1 1/2" 2" 2 1/2"
<b>Foam Core:</b>	PUR, PIR, PIR R+, Leaf (Best R value) 2.62 - 2.49 LB/FT <sup>3</sup>
<b>Joint Type:</b>	Tongue and Groove - Exposed
<b>Gasket:</b>	Open Cell Gasket - <i>Butyl available upon request</i>
<b>Steel Gauge:</b>	Interior: 22, 24, 26, 28
<b>External Face:</b>	Synthetic PVC
<b>Internal Face:</b>	Pre-painted Coated Steel (ASTM A653)
<b>Orientation:</b>	Vertical - Horizontal

Other paint systems available upon demand. For trims and accessories, ask your sales rep or contact Isocindu for more information and availability.

### Features

Monolayer panel with rigid foam insulation, synthetic PVC outer face to waterproof the building site. Designed for flat or low slope roofs and garden roofs, due to its high resistance to humidity. It is characterized by excellent waterproofing properties and high thermal insulation values.





### Options

IsoDeck Synth is a panel with great versatility, lightness and speed of installation applicable to any type of structure. Designed for installation on flat roofs or roofs with a low slope (1-2%). Available with butyl seal placed in plant.

### Benefits

- Compatibility with Flag-Soprema group systems
- Synthetic surface, upgraded to Energy Plus
- Increased resistance
- Quick installation
- Lightweight, less structure required

### Suitable for

-  **Industrial:** Warehouse, Factories, Distribution Centers
-  **Cold Chain:** Cold Chambers, Freezers, Cold Chain Facilities
-  **Commercial:** Offices, Malls, Convention Centers
-  **Architectural:** Schools, Government, Transport hubs
-  **Specialized:** Flat Roofs, Green Building, Data Centers



### Monolayer

#### Panel Weight

		Exterior Face Steel Gauge			
		28	26	24	22
<b>16.3</b>	PSF	4.92	5.58	6.07	6.89
<b>20.5</b>	PSF	4.43	4.92	5.41	6.40
<b>24.6</b>	PSF	3.94	4.59	4.92	5.58
<b>28.7</b>	PSF	3.61	4.27	4.59	5.25
<b>32.8</b>	PSF	3.44	3.94	4.27	4.92

#### Dimensional Tolerance

<b>Length</b>	$L \leq 9' 10'' \pm \frac{1}{8}''$	<b>Perpendicularity Deviation</b>	$\frac{1}{4}''$
	$L > 9' 10'' \pm \frac{3}{8}''$		
<b>Working Length</b>	$\pm 2 \text{ mm}$	<b>Misalignment of the internal metal surfaces</b>	$\pm \frac{1}{8}''$
<b>Thickness</b>	$D \leq 4'' \pm 1 \frac{1}{16}''$	<b>Bottom Sheet Coupling</b>	$F = 1 + \frac{1}{8}''$
	$D > 4'' \pm 2 \%$		

L = working length, D = panel thickness, F = sheet coupling

#### Load Chart

To obtain specific information about the panel's load capacity values, please contact an authorized Isocindu sales representative or technical specialist.

#### Thermal Insulation

Thickness	1"	1½"	2"	2½"
Value	PIR R+ 75° F Mean Temp (95° to 55°) ASTM C518			
<b>U</b> (Btu/H ft² F)	0.08	0.08	0.06	0.05
<b>R</b> (H ft² F/Btu)	12.3	11.3	15.1	18.8
Value	PIR R+ 35° F Mean Temp (55° to 15°) ASTM C518			
<b>U</b> (Btu/H ft² F)	0.07	0.08	0.05	0.04
<b>R</b> (H ft² F/Btu)	13.8	12.4	16.8	20.8

#### Joint Section

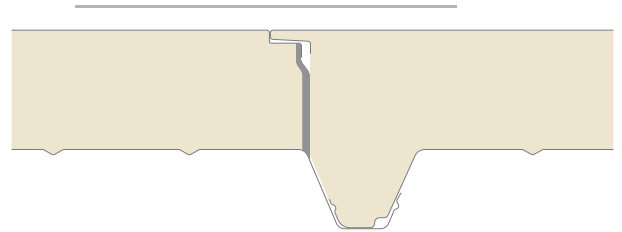

Once the fixing is completed, fill the remaining space with foam

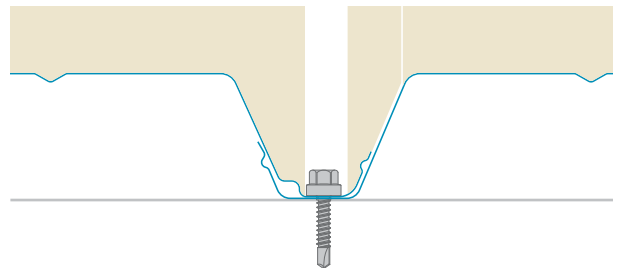
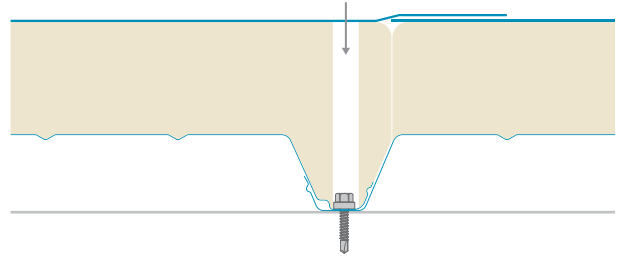

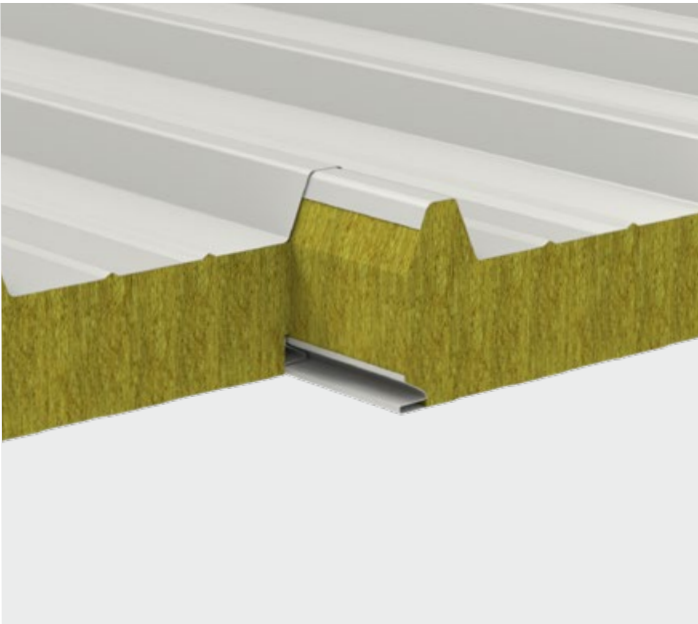

### Features

Self-supporting roof panel with double steel sheet and mineral wool core, for roofs with a slope of not less than 7%. 5-ridge profiled external sheet to increase resistance for static and dynamic loads. Visible fastening and clips with gasket.

### Options

Isofire Roof is a roofing panel suitable for new construction and renovation of industrial and commercial buildings. The rock wool insulation provides strength and protection in case of fire.

### Benefits

- Double sheet metal faced panel
- Fire resistant mineral wool
- Exposed fastening joint
- Ribbed profile for greater strength



Designed to provide fire protection from 1 to 3 hours for industrial and commercial buildings

### Specifications

<b>Length:</b>	Maximum recommended 40'
<b>Width:</b>	★ 39 3/8" - 100 cm
<b>Thickness:</b>	50*, 60*, 80*, 100, 120, 150, 170, 200 (mm)
<b>Foam Core:</b>	Mineral Wool - 100 kg/m <sup>3</sup>
<b>Joint Type:</b>	Tongue and Groove - Exposed
<b>Gasket:</b>	Open Cell Gasket
<b>Steel Gauge:</b>	<b>External:</b> 0,5 - 0,6 mm - <b>Internal:</b> 0,5 - 0,6 mm
<b>Coating:</b>	Polyester Std. G60
<b>Std. Coating:</b>	USDA Approved
<b>Orientation:</b>	Roof and wall

Other paint systems available upon demand. For trims and accessories, ask your sales rep or contact Isocindu for more information and availability.

(\*) These thicknesses are the minimum production requirement.

### Suitable for



**Industrial:** Warehouse, Factories, Distribution Centers



**Cold Chain:** Cold Chambers, Food Processing



**Commercial:** Offices, Malls, Convention Centers



**Architectural:** Schools, Halls, Government



**Specialized:** Green Building, Data Centers, Grain Sheds

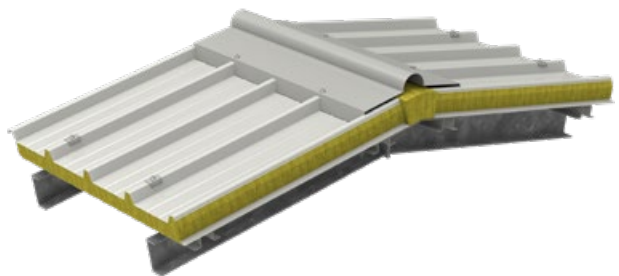

### Load Chart

Kg/m <sup>2</sup>	Distance Between 2 Simple Supports							
	Panel nominal tickness (mm)							
	50	60	80	100	120	150	170	200
Sheets 0,5mm / 0,5mm - Support 120 mm								
80	330	360	420	475	525	550	560	570
100	305	330	375	425	480	495	500	510
120	270	300	345	390	435	475	480	490
140	255	270	315	360	405	420	425	435
160	235	255	290	320	365	390	395	405
180	210	235	270	305	340	360	365	370
200	195	210	255	290	320	340	345	350
220	185	200	240	265	295	325	330	335
250	165	185	215	250	275	290	295	300

Kg/m <sup>2</sup>	Distance Between Multiple Supports							
	Panel nominal tickness (mm)							
	50	60	80	100	120	150	170	200
Sheets 0,6mm / 0,6mm - Support 120 mm								
80	350	375	430	495	545	595	605	615
100	315	340	395	445	495	540	550	560
120	280	310	355	405	450	485	490	495
140	260	290	325	370	415	440	445	450
160	245	260	300	340	375	405	410	415
180	230	245	280	315	345	380	385	390
200	210	230	265	300	330	350	355	360
220	195	220	250	280	310	330	335	340
250	170	195	230	260	290	300	305	310

### Thermal Insulation According to standard EN 14509 (no.8)

U	50	60	80	100	120	150	170	200
W/m <sup>2</sup> ·K	0.78	0.66	0.50	0.41	0.34	0.28	0.24	0.20
Btu/hft <sup>2</sup> °F	0.13	0.11	0.08	0.07	0.06	0.05	0.04	0.03
<b>K</b>	<b>50</b>	<b>60</b>	<b>80</b>	<b>100</b>	<b>120</b>	<b>150</b>	<b>170</b>	<b>150</b>
W/m <sup>2</sup> ·K	0.72	0.61	0.44	0.36	0.30	0.25	0.22	0.19
Btu/hft <sup>2</sup> °F	0.14	0.12	0.09	0.07	0.06	0.05	0.04	0.04

### Panel Weight

Steel thickness	50	60	80	100	120	150	170	200
	Values in kg/m <sup>2</sup>							
0.5/0.5	14.4	15.4	17.4	19.4	21.4	24.4	26.4	29.4
0.6/0.6	16.2	17.2	19.2	21.2	23.2	26.2	28.2	31.2

### Fire Reaction and Resistance

See page 14 & 15



### Dimensional Tolerance

<b>Length</b>	L ≤ 3 m ± 5 mm L > 3 m ± 10 mm	<b>Perpendicularity Deviation</b>	6 mm
<b>Working Length</b>	± 2 mm	<b>Misalignment of the internal metal surfaces</b>	± 3 mm
<b>Thickness</b>	D ≤ 100 mm ± 2mm D > 100 mm ± 2%	<b>Bottom Sheet Coupling</b>	F = 0 +3 mm

L = working length, D = panel thickness, F = sheet coupling

### Joint Section

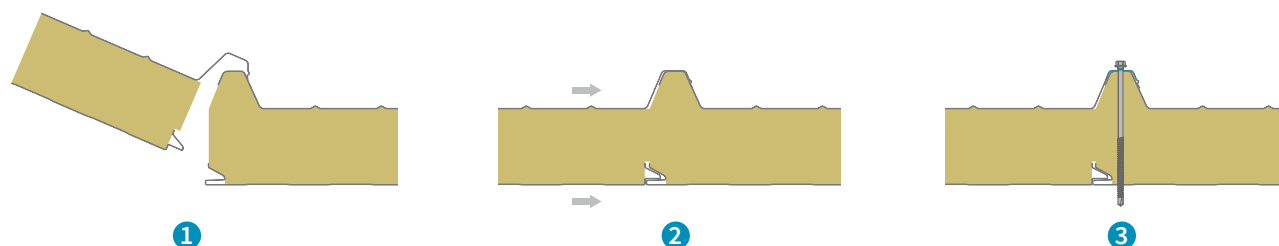

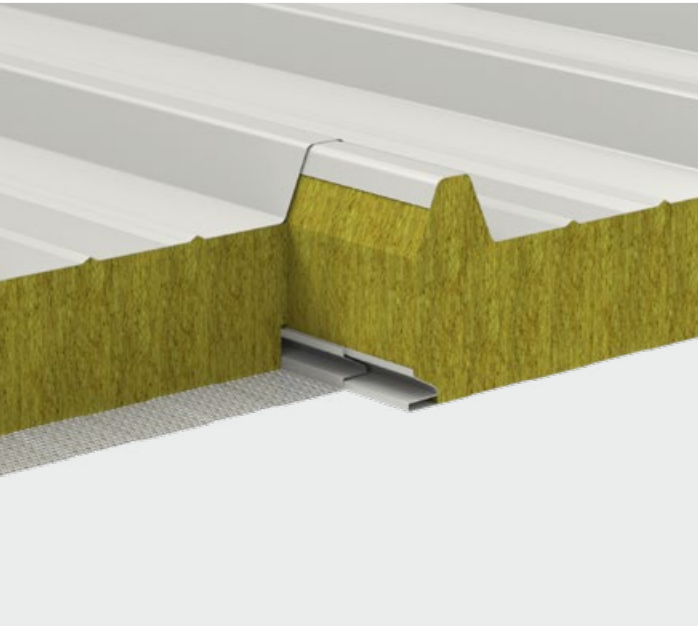

### Features

Self-supporting roof panel in double steel sheet and mineral wool core, for roofs with a slope of not less than 7%. External 5-ribbed sheet to increase static and dynamic resistance. Internal micro-perforated steel sheet to increase the acoustic insulation and absorption of the panel.

### Options

Isofire Roof Fono has an internal micro perforated sheet support capable of increasing the sound absorbing performance of the panel, reducing the decibel level, improving interior comfort. ideal for machine rooms or processing rooms.

### Benefits

- Non Combustible
- Acoustic Insulation and absorption
- Fire reaction according to class A2-s1-d0
- Superior acoustic performance



Designed to provide fire protection from 1 to 2 hours for industrial and commercial buildings

### Specifications

**Length:** Maximum recommended 40'

**Width:** ★ 39 3/8" - 1000 mm

**Thickness:** 50\*, 60\*, 80\*, 100, 120, 150 (mm)

**Foam Core:** Mineral Wool - 100 kg/m<sup>3</sup>

**Joint Type:** Tongue and Groove - Exposed

**Gasket:** Open Cell Gasket

**Steel Gauge:** External: 0,5 - 0,8 mm - Internal: 0,6 mm

**External Face:** Polyester Std. G60

**Internal face:** Micro-Perforated Steel

**Orientation:** Roof and wall

Other paint systems available upon demand. For trims and accessories, ask your sales rep or contact Isocindu for more information and availability.

(\*) These thicknesses are the minimum production requirement.

### Suitable for



**Industrial:** Warehouse, Factories



**Cold Chain:** Cold Chambers, Food Processing



**Commercial:** Offices, Convention Centers, Record Studios



**Architectural:** Schools, Government, Theaters, Halls, Atriums



**Specialized:** Healthcare, Green Building, Data Centers

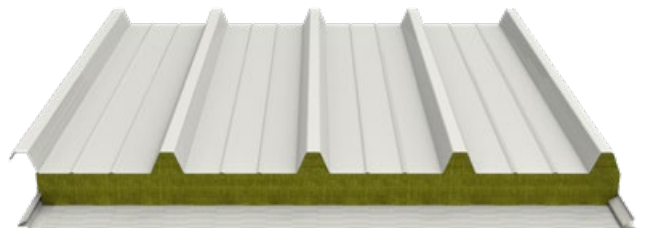

### Load Chart

Kg/m <sup>2</sup>	Distance Between <b>2</b> Simple Supports Panel nominal tickness (mm)					
	50	60	80	100	120	150
Sheets 0,5mm / 0,5mm - Support 120 mm						
<b>80</b>	285	310	365	410	455	475
<b>100</b>	265	285	325	365	415	430
<b>120</b>	230	260	300	335	375	410
<b>140</b>	220	230	270	310	350	365
<b>160</b>	200	220	250	275	315	335
<b>180</b>	180	200	230	265	295	310
<b>200</b>	165	180	220	250	275	295
<b>220</b>	160	170	205	230	255	280
<b>250</b>	140	160	185	215	235	250

Kg/m <sup>2</sup>	Distance Between <b>Multiple</b> Supports Panel nominal tickness (mm)					
	50	60	80	100	120	150
Sheets 0,6mm / 0,6mm - 120 mm support						
<b>80</b>	300	325	370	430	470	515
<b>100</b>	270	295	340	385	430	465
<b>120</b>	240	265	305	350	390	420
<b>140</b>	225	250	280	320	360	380
<b>160</b>	210	225	260	295	325	350
<b>180</b>	200	210	240	270	300	330
<b>200</b>	180	200	230	260	285	300
<b>220</b>	165	190	215	240	265	285
<b>250</b>	145	165	200	225	250	260

### Thermal Insulation

According to standard EN 14509 (no.8)

U	50	60	80	100	120	150
W/m <sup>2</sup> ·K	0.78	0.66	0.50	0.41	0.34	0.28
Btu/hft <sup>2</sup> °F	0.13	0.11	0.08	0.07	0.06	0.05
K	50	60	80	100	120	150
W/m <sup>2</sup> ·K	0.72	0.61	0.44	0.36	0.30	0.25
Btu/hft <sup>2</sup> °F	0.14	0.12	0.09	0.07	0.06	0.05

### Panel Weight

Steel Thickness	50	60	80	100	120	150
	Values in kg/m <sup>2</sup>					
<b>0.5 / 0.5</b>	13.9	14.9	16.9	18.9	20.9	23.9
<b>0.6 / 0.6</b>	15.7	16.7	18.7	20.7	22.7	25.7

### Dimensional Tolerance

<b>Lenght</b>	L ≤ 3 m ± 5 mm L > 3 m ± 10 mm	<b>Perpendicularity Deviation</b>	6 mm
<b>Working Lenght</b>	± 2 mm	<b>Misalignment of the internal metal surfaces</b>	± 3 mm
<b>Thickness</b>	D ≤ 100 mm ± 2mm D > 100 mm ± 2%	<b>Bottom Sheet Coupling</b>	F = 0 +3 mm

L = working length, D = panel thickness, F = sheet coupling

### Fire Reaction and Resistance

See page 14 & 15

### Acoustic Performance

See page 14 & 15

### Joint Section

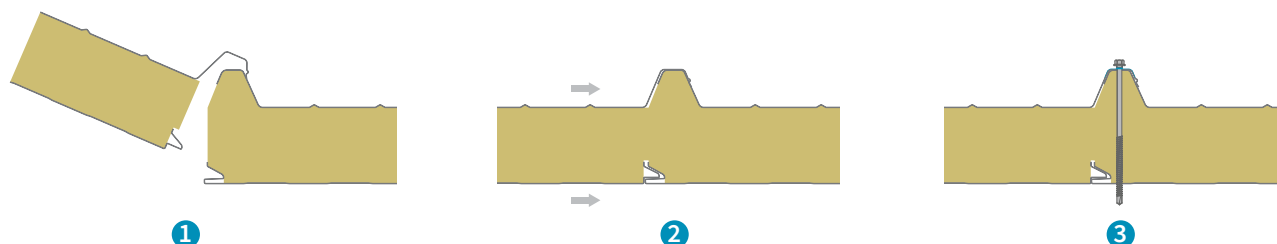

# GUIDELINES TO CHOOSE YOUR PANEL

## Accessories:

**Basic and compatible accessories:** For flashings, trims, fasteners, sealants, closure strips details, refer to catalog of flashes and accessories.

Trims and flashings shall be supplied in 26 gauge minimum.

## Steel Color:

**Color matching:** To ensure color equality, we conduct laboratory test on Steel paint using a spectrophotometer before placing a new order. The instrument assists us in reviewing differences in Lab-values, which are essential for color tone equality. The tolerances are as follow:

For light colors ( $L > 75$ )  $\Delta E < 0.8$

For medium colors ( $40 < L < 75$ )  $\Delta E < 1.0$

For dark colors ( $L < 40$ )  $\Delta E < 1.2$

\*NOTE: L = luminosity

**Color shades according to RAL:** The steel colors listed should only be interpreted as similar to RAL or Simile-RAL. In case of partial or additional deliveries, color matching is not guaranteed, as different steel coils may be used.

To avoid a color change on a surface, it will be useful to indicate to the technical and commercial area the appropriate information when ordering.

It is possible that wider color variations with respect to RAL shades may occur in PVDF coatings. In case of special colors, it is recommended to include back-up panels in the order.

## Paint Quality:

**Paint types and durability:** (PVDF, polyester, modified polyester) refer to environmental questionnaire.

**Guarantees:** For any guarantee details, please refer to the general conditions on website. For extended guarantees contact your sales agent.

For pre-painted technical information, refer to “pre-painted system” table in website.

## Packaging:

**Packaging and protection:** For packaging and handling details, refer to general conditions annex C.

## Production:

Isocindu panels are manufactured under the ASTM norms.

**ASTM A90:** Standard test method for weight (mass) of coating iron and steel articles with zinc or zinc-alloy coatings.

**ASTM A653:** Standard specification for steel sheet, Zinc-coated (galvanized) or Zinc-Iron Alloy-coated (Galvanized) by the Hot-Dip process.

**ASTM A924:** Standard specification for general requirements for steel sheet, metallic-coated by the hot-dip process.

**ASTM A1030:** Standard practice for measuring flatness characteristics of coated sheet products

**ASTM B117:** Standard practice for operating salt spray (Fog) apparatus

**ASTM C272:** Standard test method for water absorption of core materials for sandwich constructions

**ASTM C273:** Standard test method for shear properties of sandwich core materials

**ASTM C518:** Standard test method for steady-state thermal transmission properties by means of the heat flow meter apparatus

**ASTM D968:** Standard test methods for abrasions resistance of organic coatings by falling abrasive

**ASTM D1621:** Standard test method for compressive properties of rigid cellular plastics

**ASTM D1622:** Standard test method for apparent density of rigid cellular plastics

**ASTM D1623:** Standard test method for tensile and tensile adhesion of rigid cellular plastics

**ASTM D1929:** Standard test method for determining ignition temperature of plastics.

**ASTM D2244:** Standard practice for calculation of color tolerances and color differences from instrumentally measured color coordinates

**ASTM D2247:** Standard practice for testing water resistance of coatings in 100 percent relative humidity

**ASTM D2794:** Standard test method for resistance of organic coatings to the effects of rapid deformation (impact)

## Production:

**ASTM D3273:** Standard test method for resistance to growth of mold on the surface of interior coatings in an environmental chamber.

**ASTM D3359:** Standard test methods for measuring adhesion by tape test

**ASTM D3363:** Standard test method for film hardness by pencil test

**ASTM D6226:** Standard test method for open cell content of rigid cellular plastics

**ASTM E72:** Standard test methods of conducting strength tests of panels for building construction

**ASTM E84:** Standard test method for surface burning characteristics of buildings materials

**ASTM E108:** Standard test methods for fire test of roof coverings,

**ASTM D523:** Standard Test Method for Specular Gloss.

**Isocop:** basic guidelines (shape, color, installation, tolerances) Information in TDS

**Isobox:** basic guidelines (shape, color, installation, tolerances) Information in TDS.

**Isoparete:** basic guidelines (shape, color, installation, tolerances) Information in TDS.

Butyl seal is an optional factory-applied.

## Storage and Installation:

Storage and installation of the panel system shall be in accordance with the technical manual and installation of the product

Required tools and equipment: For tools and equipment please refer to general condition document, annex B in website.

## Maintenance:

It is necessary to provide a periodic maintenance according to conditions indicated in general conditions and terms document in website.

## Quality And Certifications:

**Quality Control:** Inspection procedures at different stages of production according to ISO 9001: Quality System Management

### FM Global

**FM 4880:** Class 1 Fire rating of insulated wall or wall and roof/ceiling panels, interior finish materials of coatings, and exterior wall systems.

**FM 4881:** Approval standard for class 1 exterior wall systems. **FM 4471:** Approval standard for class 1 panel roofs.

### ICC-ES Evaluation

**DIVISION:** 07 00 00- Thermal and moisture protection section  
07 40 00 – Roofing and siding panels

International Organization for Standardization (ISO)  
ISO 9001: Quality system management

## Online Material

Check out more about our guidelines, technical content and data Sheets

Contact us for more information.



# PROJECTS





# PROJECTS



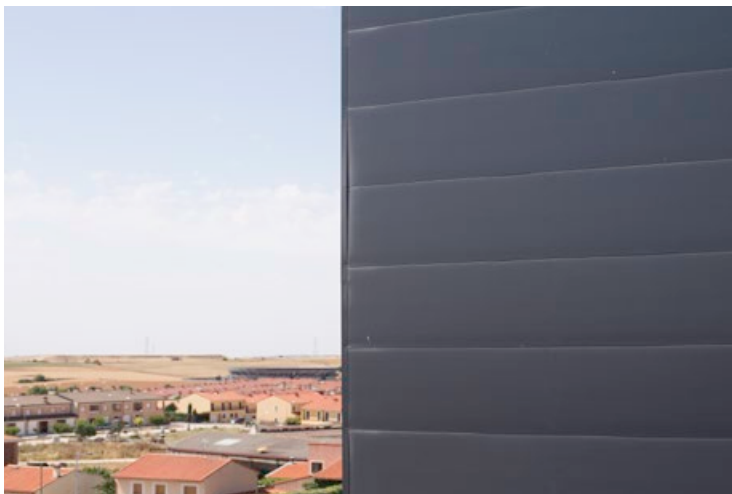

# PROJECTS







**ISOCINDU MÉXICO**

Av. Libre Comercio #137  
Puerto Interior Santa Fe III  
Silao Gto. C.P. 36275

**T. +52 472 800 7241**

**MANNI GREEN TECH USA**

179 Hughes Landing Blvd  
Suite 400, The woodlands TX  
TX 77398

**T. (281) 747-5588**

**MANNI GREEN TECH USA**

77530 Enfield Lane,  
Building D, Suite D2,  
Palm Desert, California, 92211

**T. (281) 747-5588**

**ISOPAN IBERICA**

Terragona | Spain

**ISOPAN SPA**

Verona | Italy  
Frosinone | Italy

**ISOPAN EST**

Popești-Leordeni

**ISOPAN CZ**

Praha | Czechia

**ISOPAN FRANCE**

Mérignac | France