

# Technical Manual Panel Isoparete



## TABLE OF CONTENTS

<b>ISOPARETE Range .....</b>	<b>4</b>
<i>Types of panels .....</i>	4
<i>Geometric features .....</i>	4
<i>Metal facings .....</i>	4
<i>Protection of the pre-painted facings .....</i>	5
<i>Insulation .....</i>	5
<i>Panel weight .....</i>	6
<i>Static features .....</i>	6
<i>Joint .....</i>	7
<i>Tolerances (annex D EN 1 4509) .....</i>	7
<i>Reaction to fire (EN 13501-1) .....</i>	8
<i>Restrictions of use .....</i>	8
<i>General design instructions .....</i>	9
<i>Thermal expansions .....</i>	9
<i>Fastening instructions .....</i>	12
<i>Assembly instructions .....</i>	16
<i>Package composition .....</i>	16
<i>Transport and storage .....</i>	17
<i>Packaging .....</i>	18
<i>Durability .....</i>	18
<i>Maintenance .....</i>	18
<i>Safety and disposal .....</i>	18
<b>Annex A .....</b>	<b>19</b>
<b>Annex B .....</b>	<b>21</b>
<i>Symmetrical fastening horizontal panel installation .....</i>	21
<b>Annex C .....</b>	<b>23</b>
<i>Installation phases .....</i>	23
<b>Annex D .....</b>	<b>28</b>
<i>Vacuum lifter .....</i>	28
<b>Annex E .....</b>	<b>32</b>
<i>Building details .....</i>	32

# ISOPARETE Range

Double skin metal faced wall sandwich panels with polyurethane foam insulated core, used to build curtain walls in civil and industrial buildings, featuring a tongue-and-groove concealed joint system that makes for long-lasting and aesthetically pleasing constructions.

## TYPES OF PANELS

### Isoparete box

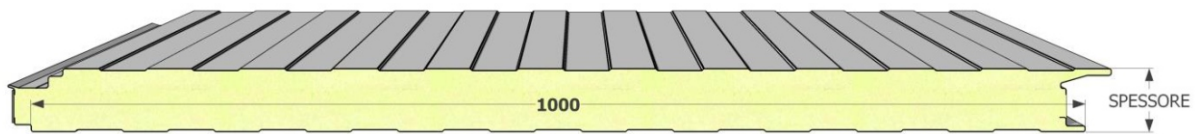

### Isoparete plissé

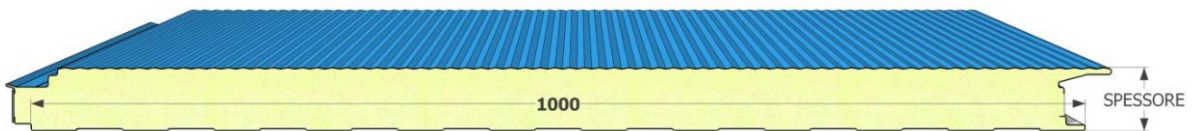

### Isoparete piano

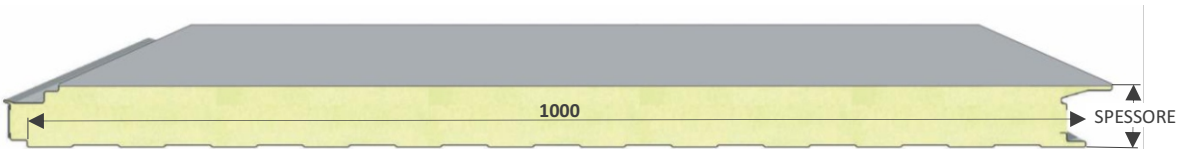

## GEOMETRIC FEATURES

	ISOPARETE BOX	ISOPARETE Plissé	ISOPARETE Piano
<b>Length</b>	Up to maximum transportable		
<b>Useful Pitch (in-mm)</b>	39"-1000		
<b>Insulating Thickness (in-mm)</b>	1"5/8-41,3; 2"-50,8; 2"1/2-63,5; 3"-76,2; 4"-101,6; 5"-127; 6"-152,4		
<b>External face</b>	micro-ridged lightly profiled metal sheet	"diamond" lightly profiled metal sheet	flat metal sheet
<b>Internal face</b>	micro-ridged lightly profiled metal sheet		

## METAL FACINGS

- Hot dip galvanised steel by SENDZIMIR continuous process (UNI EN 10346) and pre-painted by means of a coil coating continuous process with different painting cycles based on end use (see: "Guide to Choosing Pre-painted").
- 3000 or 5000 series aluminium alloys with pre-painted finish with the cycles mentioned in the previous point, with a natural or embossed effect.
- Stainless steel AISI 304 finishing 2B, according to EN 10088-1.

- In case of aluminium facings, these must be preferably applied on both sides: in fact, if different materials are used on the two sides, the panel may distort and bend due to the different thermal expansion coefficients of the sheets.
- For stainless steel facings, one should take into account the possible appearance of flaws that are highlighted by such reflecting surfaces.

### PROTECTION OF THE PRE-PAINTED FACINGS

All pre-painted metal facings are supplied with an adhesive polyethylene protective film that prevents damage to the paint layer. If the material is specifically requested without protective film, Isopan assumes no liability in case of damages to the paint. The protective film that covers the pre-painted panels must be completely removed during assembly and, in any case, within sixty days after the material preparation.

It is also recommended not to expose the panels covered by a protective film to direct sunlight.

### INSULATION

Made with rigid polyurethane foam, having the following physical and mechanical features:

- Compressive strength  $\geq 0.11$  MPa (at 10% deformation)
- Tensile strength  $\geq 0.10$  MPa
- Shear strength  $\geq 0.10$  MPa
- Thermal conductivity coefficient  $\lambda = 0.022$  W/mK
- The 95% closed cells guarantee an anhygroscopic structure
- Operating temperature:
 

minimum	- 40 °C
maximum	+ 80 °C

Foaming agent: N-Pentane in accordance with the Montreal protocol

Thermal transmittance coefficient 75° F Mean Temp (23.9 °C)

Panel thickness (in)	1" 5/8	2"	2" 1/2	3"	4"	5"	6"	8"
Panel thickness (mm)	41,3	50,8	63,5	76,2	101,6	127	152,4	203,2
<b>R [m<sup>2</sup>K/W]</b>	2.01	2,48	3,10	3,72	4.96	6.20	7.44	9.92
<b>R [Hft2F/Btu]</b>	11.44	14,08	17,61	17,61	28.17	35.21	42.25	56,34

Thermal resistance coefficient 35°F Mean Temp (1.67 °C)

Panel thickness (in)	1" 5/8	2"	2" 1/2	3"	4"	5"	6"	8"
Panel thickness (mm)	41,3	50,8	63,5	76,2	101,6	127	152,4	203,2
<b>R [m<sup>2</sup>K/W]</b>	2.25	2,77	3,46	4.16	5.54	6.93	8.32	11.09
<b>R [Hft2F/Btu]</b>	11.44	15,75	19.69	23.62	31.50	39.37	47.24	62.99

## PANEL WEIGHT

Sheet thickness (GA)	Nominal panel thickness								
	in	1" 5/8	2"	2"1/2	3"	4"	5"	6"	8"
	mm	41,3	50,8	63,5	76,2	101,6	127	152,4	203,2
<b>26/26</b>	PSF	2.05	2.14	2.24	2.33	2.52	2.70	2.89	3.27
<b>24/26</b>	PSF	2.42	2.51	2.61	2.70	2.85	3.04	3.26	3.64
<b>24/24</b>	PSF	2.75	2.85	2.94	3.04	2.22	3.41	3.60	3.97
<b>22/26</b>	PSF	2.70	2.70	2.88	2.98	3.16	3.35	3.54	3.91

## STATIC FEATURES

ISOPARETE panels are self-supporting according to the UNI EN 14509 definition: "...panel capable of supporting, by virtue of its materials and shape, its own weight and in case of panel fixed to spaced structural supports, all applied loads (snow, wind, air pressure), and transmitting these loads to the supports.", depending on the type of metal facings, their thickness and the thickness of the thermal insulating core.

**The resistance values refer to a panel assembled horizontally and subject to the action of a distributed load that simulates the action of wind pressure;** the calculation method used by ISOPAN does not consider the thermal effects, which are verified by the designer. Depending on the weather conditions of the installation location and the colour of the external face, if the designer feels a detailed verification of the stresses caused by thermal actions and long-term effects is necessary, he/she should contact the IsoCindu Technical Office. The designer is still responsible for checking the fastening systems, based on their number and the way they are placed.

Below are some examples of indicative load bearing tables:

**The indications included in the following tables doesn't take into account the thermal load effects. Furthermore, the indicative values reported may not be used to replace the project calculations drawn up by a qualified technician, who will have to validate these instructions in accordance with the laws in the country of installation of the panels.**

- panel on two supports:

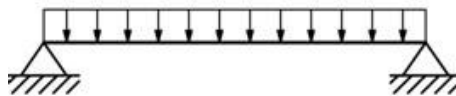

STEEL SHEETS (Cal 26 / 26) Simple support 4 5/8"								
UNIFORMLY DISTRIBUTED LOAD (PSF)	NOMINAL PANEL THICKNESS in							
	1" 5/8	2"	2" 1/2	3"	4"	5"	6"	8"
	MAXIMUM SPAN ft-in							
<b>10.24</b>	10' 5 5/8"	12' 5 5/8"	14' 5 5/8"	17' 5/8"	19' 8 5/8"	22' 1 5/8"	25' 7 5/8"	29' 1 5/8"
<b>12.29</b>	9' 10"	11' 5 3/4"	13' 5 3/8"	15' 6 1/2"	18' 4 3/8"	20' 10"	22' 7 5/8"	26' 1 5/8"
<b>16.38</b>	8' 6 1/4"	10' 1 5/8"	11' 5 3/4"	13' 7 3/8"	16' 7/8"	18' 8 3/8"	20' 8"	24' 2"
<b>20.48</b>	7' 6 1/2"	9' 1/4"	10' 5 7/8"	12' 3 5/8"	14' 9 1/8"	16' 10 3/4"	18' 8 3/8"	22' 2 3/8"
<b>24.57</b>	6' 10 5/8"	8' 2 3/8"	9' 6 1/8"	11' 1 3/4"	13' 7 3/8"	15' 7"	17' 2 5/8"	20' 8 5/8"
<b>28.67</b>	6' 2 3/4"	7' 6 1/2"	8' 8 1/4"	10' 1 5/8"	12' 7 1/2"	14' 7 1/8"	15' 8 7/8"	19' 2 7/8"
<b>32.77</b>	5' 8 7/8"	6' 10 5/8"	8' 3/8"	9' 6 1/8"	11' 11 5/8"	13' 7 3/8"	15' 1"	18' 7"
<b>36.86</b>	5' 4 7/8"	6' 4 3/4"	7' 6 1/2"	9' 1/4"	11' 3 3/4"	12' 11 1/2"	13' 11 1/4"	17' 5 1/4"
<b>40.96</b>	5' 5/8"	6' 3/4"	7' 5/8"	8' 4 3/8"	10' 7 7/8"	12' 3 5/8"	13' 5 3/8"	16' 11 3/8"

- panel on multiple supports:



STEEL SHEETS (Cal 26 / 26) – Multi-Support 4 5/8"								
UNIFORMLY DISTRIBUTED LOAD (PSF)	NOMINAL PANEL THICKNESS in							
	1" 5/8	2"	2" 1/2	3"	4"	5"	6"	8"
	MAXIMUM SPAN ft-in							
10.24	12' 5 5/8"	14' 9 5/8"	17' 5/8"	20' 2 5/8"	22' 11 5/8"	24' 7 5/8"	27' 2 5/8"	28' 8 5/8"
12.29	11' 1 3/4"	13' 5 3/8"	15' 5"	18' 4 3/8"	20' 8"	21' 11 3/4"	26' 4 7/8"	27' 10 7/8"
16.38	9' 6 1/8"	11' 5 3/4"	13' 5 3/8"	15' 7"	17' 2 5/8"	18' 8 3/8"	24' 3 1/4"	25' 9 1/4"
20.48	8' 6 1/4"	10' 2"	11' 9 5/8"	13' 9 1/4"	15' 5"	16' 7/8"	20' 11 7/8"	22' 5 7/8"
24.57	7' 6 1/2"	9' 2 1/8"	10' 5 7/8"	12' 1 5/8"	13' 7 3/8"	14' 7 1/8"	18' 2 1/2"	19' 8 1/2"
28.67	6' 6 5/8"	8' 2 3/8"	9' 8 1/8"	11' 1 3/4"	12' 5 1/2"	13' 5 3/8"	16' 6 3/4"	18' 3/4"
32.77	6' 3/4"	7' 2 1/2"	8' 8 1/4"	10' 2"	11' 7 3/4"	12' 3 5/8"	15' 1"	16' 7"
36.86	5' 2 7/8"	6' 6 5/8"	7' 10 3/8"	9' 4 1/8"	11' 1 3/4"	11' 7 3/4"	13' 9 1/4"	15' 3 1/4"
40.96	4' 9"	5' 10 3/4"	7' 5/8"	8' 8 1/4"	10' 4"	10' 11 7/8"	13' 1 3/8"	14' 7 3/8"

## JOINT

The joint is fitted with a continuous sealing gasket, inserted during production. The shape of the joint is specifically designed to ensure product functionality.

The outer part of the male-female junction of the panel can be made with compensation leak (about 17mm) or without, as shown in the figure.

### ISOPARETE Box joint (with compensation leak)

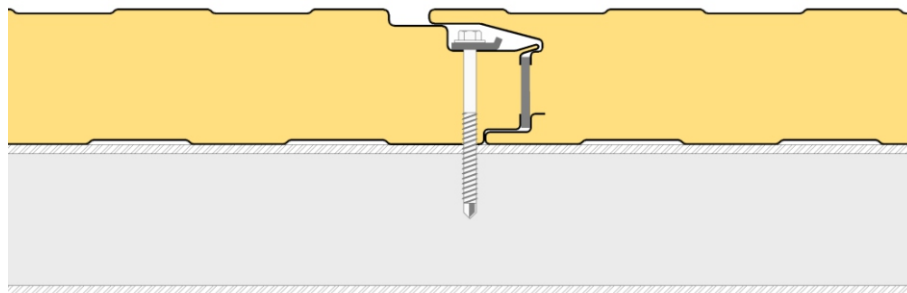

### ISOPARETE Box joint (without compensation leak)

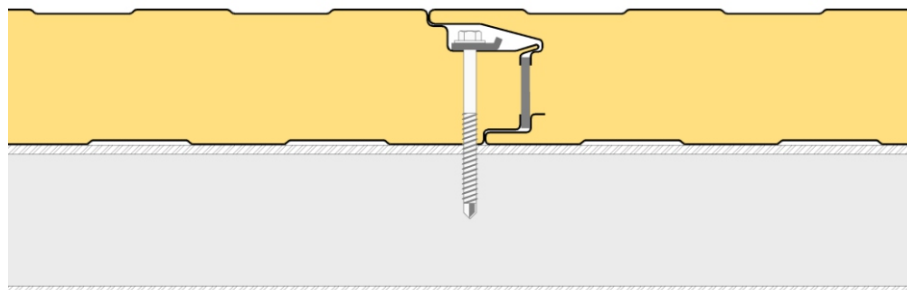

### Tolerances (annex D EN 14509)

- Facing thickness: according to the reference standards for the products used
- Panel thickness: nominal,  $\pm 2$  mm
- Length: if  $\leq 3000$  mm  $\pm 5$  mm; if  $> 3000$  mm  $\pm 10$  mm

## REACTION TO FIRE (EN 13501-1)

The reaction to fire indicates the degree to which a material participates in the fire it is subjected to.

The standard of reference for the reaction to fire classification of building materials is **EN 13501-1** (Fire classification of construction products and building elements). This standard specifies:

**Euroclasses:** the standard distinguishes seven classes, with increasing contribution to fire, from A1 (non-combustible product) to F (product not tested/not classified).

**Smoke:** opacity growth speed of the smoke

- **s1** no smoke emission
- **s2** low smoke emission
- **s3** strong smoke emission

**Burning droplets:** fall of burning particles

- **d0** no burning particles
- **d1** few burned particles
- **d2** many burned drops

The fire classification of the panel depends on the type of polyurethane foam used and the thickness of the insulation; for further information, please refer to the Isopan catalogue, the website [www.isopan.com](http://www.isopan.com) or contact the Technical Department.

## RESTRICTIONS OF USE

- A thermohygroscopic check should be performed during the design stage. In certain conditions (e.g. high indoor humidity level) condensation can appear on the internal face of the panel with consequent dripping inside the building. If these conditions persist long enough, they can accelerate the natural degradation of the organic facing and the support itself.
- **Due to solar radiation, the external face of the panel can reach relatively high temperatures. In some cases, it can reach a temperature of 80÷90°C.** A high temperature gradient should cause the panel deflection the panel and wrinkle the metal sheet. Isopan recommends a minimum thickness of 0.6 mm for the external side support. The occurrence of the problem may be limited with an accurate design, taking into account environmental conditions, length, colour of the panels and sheet thickness. (**See the "Thermal expansion" section**).
- If an aluminium sheet is used as external face, it is necessary to consider the possible distortions of the panel (bending) due to the different thermal expansion coefficients.

## GENERAL DESIGN INSTRUCTIONS

The wall panels generally require, during the design phase, a structure able to absorb the external loading stress that will not submit the panels to excessive and permanent distortions to the detriment of their basic characteristics. When choosing the panel types during the design phase, you should consider some parameters related to environmental actions like:

- **Wind action:** depends on the climatic area where the building is installed; the values fluctuate based on wind speed, with subsequent greater or lesser load pressure on the exposed surfaces (affects the type and number of panel fastening elements). For this particular panel (with concealed fastening elements), wind action in depression should be considered, bearing on joint resistance and fastening points, and it is required to use the specific Isopan plate on each screw to distribute stress (we recommend consulting with the ISOPAN Technical Department).
- **Thermal stress:** largely depends on the colour of the external surface of the panel and the building exposure, and can induce significant system deformations.
- **Atmospheric corrosion:** depends on the environment where the panels are installed (marine, industrial, urban, rural); mainly affects the degree of corrosivity on the panel surfaces. In this regard, suitable metallic or organic facings should be chosen (refer to the available documentation or contact the Isopan Technical Department).

In order to make up for possible lack of material due to damages during handling and assembly, Isopan recommends procuring spare panels (quantity equal to approximately 5% of the total).

## THERMAL EXPANSIONS

All the materials used for the construction of walls, especially metals, are subject to **thermal expansion and contraction** phenomena, resulting from the effect of temperature changes. The stresses due to thermal expansions of the metal sheet act on the siding and can cause functional and structural product anomalies, particularly in case of:

- Significant panel length ( $L > 5000$  mm);
- Solar radiation;
- Medium and dark colours;
- High panel thickness;
- Inadequate thickness of the metal support.

Material	Thermal expansion coefficient ( $^{\circ}\text{C}^{-1}$ )
Steel	$12.0 \times 10^{-6}$
Stainless steel AISI 304	$17.0 \times 10^{-6}$

-Values of linear thermal expansion coefficients-

Type of facing		Surface temperature ( $^{\circ}\text{C}$ )	
		Min.	Max.
Insulated	Light	-20	+60
	Dark	-20	+80

Where "insulated" means that an insulating core is inserted between the external sheet and the structure; "light or dark" means the surface colour of the sheet.

-Temperature range-

For high surface temperatures, the linear extension of the metal face must be absorbed by the system; cyclic temperature changes related to the day-night or freeze-thaw fluctuations create uncontrollable cyclic stresses that fatigue the support elements. These stresses may cause flaws and undulations in wall panels and, in more severe cases, even wrinkling phenomena. These issues may be overcome by complying with the requirements:

- Calculate in advance the deformation induced on the panel by the thermal expansion
- Do not use dark colours on long panels
- Use suitable thickness of the metallic supports (minimum 0.6 mm to be assessed based on specific design issues)
- Segment the panels
- Use a panel fastening system able to offset the shift caused by the excessive thermal expansions; this solution is particularly important when using panels with aluminium support (see for example figure below).

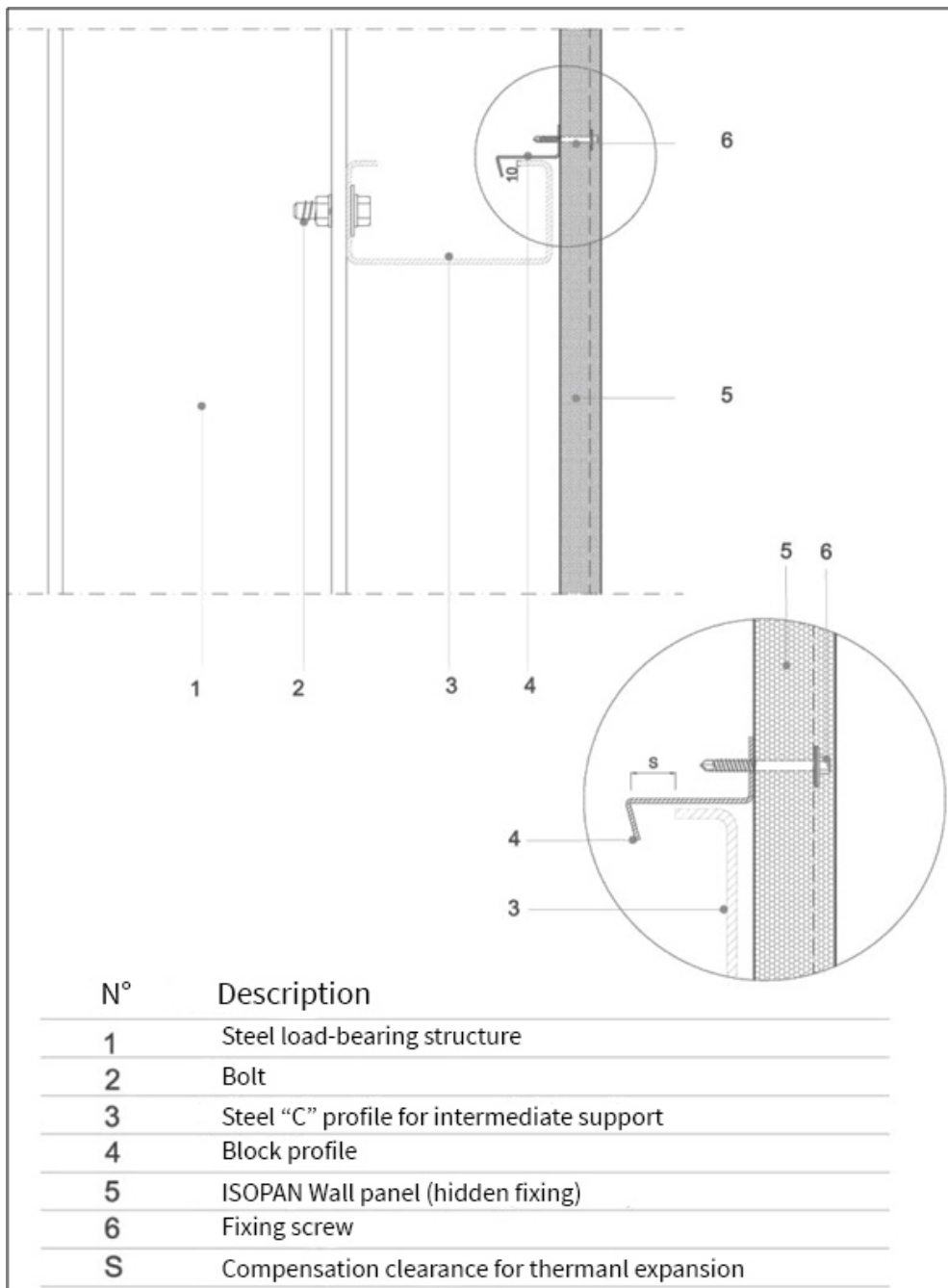

If necessary, internal supports are provided:

Solution 1

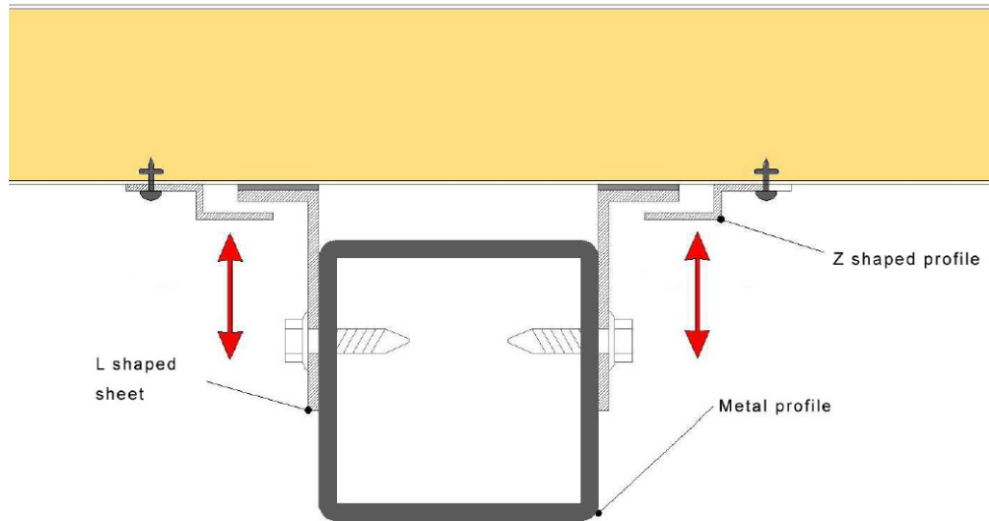

Solution 2

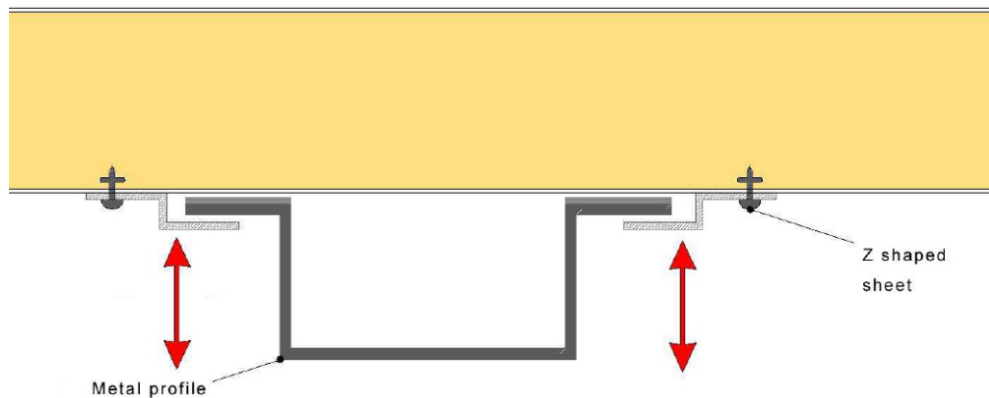

Therefore, the assembly phase is critical for the following reasons:

- **the very nature of the mechanical joint** the profiles of the tongue-and-groove joints are accurate and, therefore, due to the effect of linear elongation and bowing caused by solar irradiation, the assembly phase can be difficult or compromised;
- **the bending stiffness of the panel** panels with high thicknesses have a higher stiffness than those with average-low thicknesses; any abnormalities during assembly due to thermal effects cannot be resolved with "adjustments" during installation, causing jointing difficulties.

Sandwich panels with dark external faces that reach external surface temperatures of around +80°C (as described in UNI EN 14509) are submitted to a deflection perpendicular to the longitudinal axis of the panel. This deflection, which depends on the temperature difference between the external and internal metal sheet, is particularly noticeable for long simple span panels. To limit this particularly non-aesthetic deflection, Isopan suggests complying with the maximum spans specified in the following tables.

It is important to emphasise that for this type of panel (with concealed fastening system), the mechanical action induced by the sum of thermal loads and wind loads in depression must be considered relevant for proper joint functionality and stability. ISOPAN suggests not to exceed the maximum spans between supports shown in the following tables:

THERMAL LOAD TABLES WITH $\Delta T = 55^{\circ}\text{C}$ DARK EXTERNAL METAL SHEET COLOUR - GROUP III							
Concealed fastening with a screw on every support with load spreading plate							
Dark steel sheet 24 (GA) - support 4 5/8"							
$\Delta T = 55^{\circ}\text{C}$ (dark external sheet colour - Group III)							
	Nominal panel thickness (in)						
	1" 5/8	2"	2" 1/2	3"	4"	5"	6"
	Maximum span (ft-in)						
	4' 1 3/8"	5' 2 7/8"	6' 2 3/4"	8' 2 3/8"	11' 3 3/4"	14' 1 1/4"	14' 9 1/8"

(\*) The calculation considers a deformation limit equal to 1/300 of the span to limit panel deformation due to thermal loads induced by the dark colour of the external metal sheet

## FASTENING INSTRUCTIONS

The purpose of the fastening elements is to efficiently anchor the panel to the load-bearing structure; the type of fastening unit depends on the type of support. The number and position of the fastening elements must guarantee resistance to the stresses induced by dynamic load, which can also exist in depression.

Appropriately coated carbon steels or austenitic type stainless steels must be chosen as suitable materials to fasten panels. You should pay particular attention to the compatibility of the steel and aluminium materials in order to prevent the formation of galvanic currents.

### Fastening methods

Fastening varies depending on the project to be implemented and site application system of the panels. Isopan recommends using double-threaded screws with washer and sealing gasket with 19 mm minimum diameter.

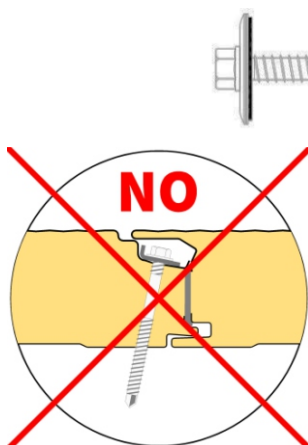

**A**

Incorrect tightening due to a high torque applied to the screw with marked deformations of the sheet metal. **In this situation the optimal closing of the interlocking is no longer guaranteed, therefore, the aesthetic functionality of the product remains compromised.**

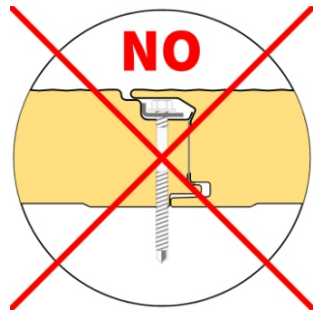

**B**  
Incorrect tightening due to the torque applied to the screw being insufficient to ensure correct fastening of the panel to the structure.



**C**  
Correct tightening obtained by applying sufficient torque to the screw to ensure fastening of the panel to the structure.

### Screw length

The correct length of the screw depends on the panel thickness and on the type of support (steel, wood).

Fixing Support	Screw Length (mm) for the joint	Screw Length (mm) outside the joint
<b>Steel</b>	Panel thickness + 1/2"	Panel thickness + 1 1/8"
<b>Wood</b>	Panel thickness + 7/8"	Panel thickness + 1 1/2"

### Load spreading plate (recommended by Isopan)

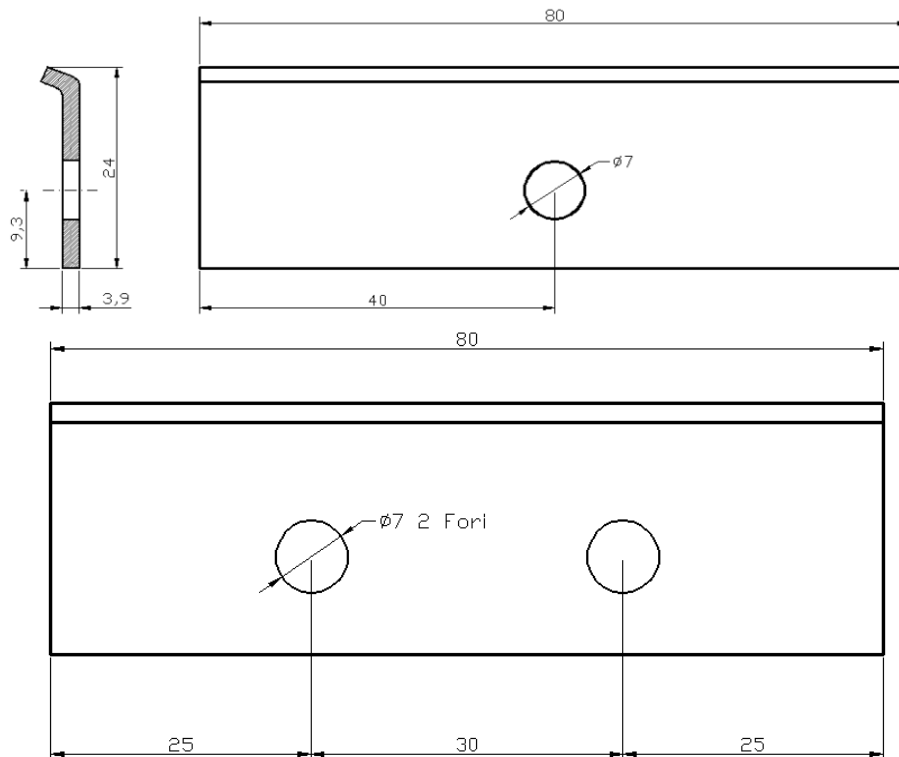

### Wall panel fastening

The panels are usually anchored to metal sheets positioned transversally to the length of the panels, which are, in turn, appropriately fastened to the load-bearing structure of the building as required by the design for stability. The width of the support must be at least 50 mm; said width must be checked and, if necessary, increased based on design requirements. In the event of butt jointing between two panels, said width must be at least 120 mm. Panels must be fastened to the load-bearing structure using the devices identified and sized in the design. The number of fastening elements varies depending on the different climatic conditions where the building is situated. Normally, for each panel, a fastening unit must be used at each support sheet. In case of long spans and/or in particularly windy areas, the density of the fastening elements must be established by the designer on a case by case basis, appropriately increasing the number of fastening elements and positioning the second screw as shown:

For wind loads in depression on the basis of experimental tests, we consider a percentage reduction coefficient  $\phi$ , which can be applied to the spans described in the "static features" paragraph, according to the following tables (only approximate values are shown for limited loads in depression).



LOADS IN DEPRESSION							
Concealed fastening with a concealed screw and load spreading plate							
Load (kg/m <sup>2</sup> )	Panel nominal thickness (in)						
	1" 5/8	2"	2" 1/2	3"	4"	5"	6"
	$\phi$ depression(%)						
50	25%	30%	50%	55%	55%	55%	60%
60	25%	35%	45%	55%	60%	60%	65%
80	40%	50%	55%	60%	65%	70%	70%
100	55%	60%	65%	65%	70%	70%	75%
120	60%	65%	70%	70%	75%	75%	80%
140	70%	70%	75%	75%	80%	80%	80%

LOADS IN DEPRESSION TABLES							
Concealed fastening with a concealed screw and load spreading plate							
Uniformly distributed load (kg/m <sup>2</sup> )	Nominal panel thickness (in)						
	1" 5/8	2"	2" 1/2	3"	4"	5"	6"
	Maximum span (ft-in)						
50	7' 10 3/8"	8' 8 1/4"	7' 2 1/2"	7' 6 1/2"	9' 4 1/8"	9' 6 1/8"	9' 8 1/8"
60	7' 4 1/2"	7' 4 1/2"	7' 4 1/2"	6' 10 5/8"	7' 8 1/2"	7' 10 3/8"	8' 0 3/8"
80	5' 1"	5' 1"	5' 1"	5' 4 7/8"	5' 10 3/4"	6' 0 3/4"	6' 2 3/4"
100	3' 3 1/4"	3' 7 1/4"	3' 7 1/4"	4' 3 1/8"	4' 7"	4' 9"	4' 11"
120	2' 7 1/2"	2' 9 3/8"	2' 9 3/8"	3' 3 1/4"	3' 5 1/4"	3' 7 1/4"	3' 9 1/4"
140	1' 9 5/8"	2' 1 1/2"	2' 1 1/2"	2' 5 1/2"	2' 5 1/2"	2' 7 1/2"	2' 9 3/8"

**Using two additional through fastening screws (later concealed by the joint covers) does not require changing the span set out in the "static features" paragraph.**

ISOPAN recommends some solutions to cover the exposed panel fastening using appropriate flashing systems (joint covers). **(See Annex B)**

## ASSEMBLY INSTRUCTIONS

The correct sequence of assembly operations is the following:

### Preliminary operations

- Verify that the supports are properly aligned.
- Pay particular attention to the contact points between the supports and the panel support plates to avoid phenomena linked to electrochemical corrosion if non-compatible metals are coupled. For this purpose, elastomer or expanded resin strips may be applied as separators.
- Ensure that the site area has appropriate storage and handling capacity in order to prevent material damage.
- Use suitable tools (toothed circular saw, jigsaw, shears, nibbler) for on-site cutting operations. The use of equipment that produces metallic sparks (e.g. abrasive discs, disc cutter) is absolutely not recommended.
- Use suitable handling systems, particularly for long or heavy panels, in order to prevent safety risks on site and damages to the product.

Using acetic silicones is prohibited as they tend to attack the pre-painted galvanised sheet and form incipient oxidation. It is best to use single component sealant silicones with neutral curing that tend to harden due to the air humidity and, being free of solvents, do not attack the paint.

### Assembly

- Apply the basic flashing (when provided) to the foot of the wall, as well as the flashing that must be installed before the wall, such as drip edges, roof fittings, etc.
- Remove the protective film from the panels, if any.
- Apply the panels starting from the bottom of the wall, or the side end in case of vertical assembly, taking care to perform correct joints and to ensure they are plumb.\*
- Systematically fasten the elements after ensuring they match correctly. The fastening screw must be inserted orthogonally to the panel.
- If the wall height involves the need to assemble panels vertically, the junction is made at the frame and requires appropriate use of shaped fitting flashing (ridge caps, drip edges, etc.).
- Use "U" ridge caps and drip edges for doors and window frames.
- Apply the finishing elements (angle bars, perimeter edgings, fittings).
- Check and clean the walls, with particular attention to metal scraps, fastenings and fittings with door and window frames.
- For horizontal installation, the groove part of the panel must always be facing downward in order to prevent rainwater from stagnating and to promote normal run-off.

**\*Note: it is mandatory to adhere to the correct installation direction of the panels during assembly .**

## PACKAGE COMPOSITION

The panels are normally supplied packaged and wrapped with extensible polyethylene film; the standard composition of the package is as shown below:

Panel thickness (in)	1" 5/8	2"	2" 1/2	3"	4"	5"	6"
Panel thickness (mm)	41,3	50,8	63,5	76,2	101,6	127	152.4
<b>No. of panels per package</b>	18	15	12	9	7	6	5

Package compositions and types of packaging other than standard must be explicitly requested when ordering.

## **TRANSPORT AND STORAGE**

### **Lorry loading**

- The packages of panels are loaded on lorries, usually two in width and three in height. The packages include polystyrene spacers at the base, which are thick enough to allow for the lift straps.
- The goods are arranged on the vehicles so as to ensure safe transportation and integrity of the material, in accordance with the requirements of the carrier, who is solely responsible for load integrity. Pay special attention to ensure the weight bearing on the bottom package, as well as the pressure exerted in the tying points, do not cause damage and the straps do not distort the shape of the product in any way.
- Isopan assumes no liability for loading lorries that are already partially occupied with other materials, or that do not have a suitable loading floor.

The customer who will pick up the material must instruct drivers for the purpose.

### **Lorry unloading with crane**

- Use any type of crane equipped with lifting beam and equipped straps. Isopan can advise customers on the choice of lifting beams and straps. By using correct lifting systems, the panels will not be damaged.
- Never use chains or metal cables for lifting under any circumstances. As a general rule, sling the packages leaving about 1/4 of their length protruding from each end.

### **Lorry unloading with forklifts**

- If the lorries are unloaded using a forklift, the length of the packages and their possible bending should be taken into account in order to prevent damages to the bottom of the package.
- The forks must be wide and long enough in order not to damage the product. When possible, protective material against surface abrasion and scratches should be applied between the fork and the package.

### **Indoor storage (Annex A)**

- The materials must be stored in ventilated indoor facilities that are free of dust and humidity and not subject to temperature changes.
- Moisture that can penetrate (rain) or form (condensation) between two panels can damage the facings since it is particularly aggressive on metals and facings, with subsequent oxidation.
- Pre-painted facings may be more exposed to the negative consequences of combined heat/humidity conditions.

### **Outdoor storage (Annex A)**

- If the packages and accessories are stored outdoors, the surface must absolutely be inclined longitudinally to prevent the accumulation of moisture and allow water run-off and natural air circulation.
- If storage is not shortly followed by pick-up for installation, it is advisable to cover the packages with a protective tarp, assuring impermeability as well as adequate ventilation to prevent condensate from accumulating and puddles of water from forming.

### **Storage terms (Annex A)**

- Based on experience, in order to maintain original product performance, continuous indoor storage in closed and ventilated facilities should not exceed six months, while outdoor storage should never exceed sixty days from the date of production. These terms refer to the properly stored product, as instructed in the "storage" chapter in Annex A. However, the materials must always be protected against direct sunlight, as it may cause alterations.
- In case of transport in containers, the products must be removed from the containers as soon as possible and, however, no later than 15 days from the loading date, to prevent deterioration of the metal facings and organic coatings (e.g. blistering). Moisture inside the container must absolutely be avoided. Upon customer request, Isopan can provide special packages that are more suitable for transport in containers.

## **PACKAGING**

Isopan suggests carefully choosing the type of packaging depending on destination, type of transport, conditions and length of storage.

To choose the correct type of packaging, please refer to the document "**Packaging and Services**" on [www.isopan.com](http://www.isopan.com).

## **DURABILITY**

Product durability depends on the intrinsic features of the panel used in relation with its final use. The panel, including the features of the metal sheets, must be chosen after a proper design of the wall.

In this regard we recommend, if necessary, using the Isopan documentation, also available on the web ([www.isopan.com](http://www.isopan.com)), and/or the reference standards.

## **MAINTENANCE**

All types of facings, including those made with metal sandwich panels, require maintenance.

The type and frequency of maintenance activities depend on the product used for the outer facing (steel, aluminium); in any case, we recommend periodically inspecting the building (at least once a year), in order to assess its conditions.

In order to maintain the aesthetic and physical properties of the elements and to extend the efficiency of the protective facing, it is also recommended to regularly clean the wall, paying special attention to the areas that could facilitate rain water stagnation, where substances that are harmful to the durability of the metal sheet may be concentrated.

If you notice any problems following an on-site inspection, you must react immediately in order to restore the initial general conditions (e.g. restoring the paint where there are local abrasions or scratches).

At the customer's request, Isopan can provide useful information to solve some problems related to this topic.

## **SAFETY AND DISPOSAL**

Pursuant to Directive 68/548/EEC the sandwich panel does not require labelling. To meet customers' requirements, Isopan has drawn-up a "Technical details for safety" document, to be referenced for any kind of information related to safety.

**Caution: all information contained in the product data sheets must be validated by a qualified technician according to the laws in force in the country of installation of the panels.**

Technical data and features are not binding. Isopan reserves the right to make changes without prior notice; the latest documentation is available on our website [www.isopan.com](http://www.isopan.com). For whatever is not explicitly specified herein, please refer to the "General conditions of sale of the corrugated metal sheets, insulated metal panels and accessories". All the products that fall under the EN 14509 standard field of application are CE marked.

This document and all the elements it contains are the exclusive property of Isopan. Reproduction, even in part, of the texts and any images contained herein without the author's written authorisation is forbidden.

**Copyright © 2015 – ISOPAN S.p.A.**

# Annex A

## LORRY UNLOADING WITH CRANE

For lifting, the packages must always be sling in at least two points. The distance between them must be no less than half the length of the packages.

Lifting should be possibly carried out using synthetic fibre straps (Nylon) no thinner than 10 cm, so that the load is distributed on the strap and does not cause distortion.

(see Figure 1)

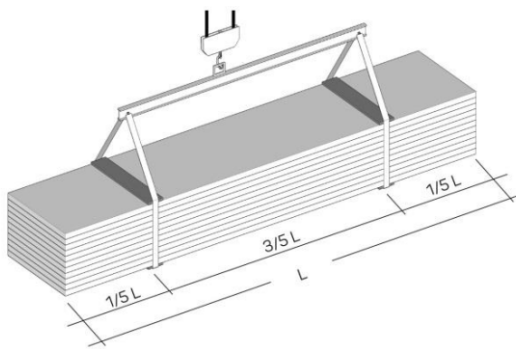

Figure 1

Suitable spacers must be placed under and above the package, made of sturdy solid wood or plastic elements to avoid direct contact of the strap with the package.

These spacers must be at least 4 cm longer than the width of the package and be at least as wide as the strap.

Make sure that the straps and supports cannot move during lifting and that manoeuvres are performed cautiously.

## LORRY UNLOADING WITH FORKLIFTS

If the lorries are unloaded with a forklift, take into account the length of the packages and their possible bending in order to avoid damaging the bottom of the package and/or to the extreme failure limit of the panels.

We recommend using forklifts that are suitable for handling panels and similar products.

## STORAGE

The packages must always be kept off the ground both in the warehouse and, more so, at the construction site. They must have plastic foam supports with flat surfaces longer than the width of the panels and at a distance adequate to the features of the product.

The packages should preferably be stored in dry facilities to prevent stagnation of condensation water on inner, less ventilated, elements, which is particularly aggressive on metals, resulting in the formation of oxidation.

The panels must be stored in dry ventilated facilities; should this not be possible, open the packages and ventilate the panels (spacing them from one other). If the panels remain packaged outdoors, the galvanised facing may oxidise (white rust) even after a few days, due to electrolytic corrosion.

The panels must be stored to facilitate water run-off, especially when it is necessary to temporarily store them outside (see Figure 2).

If storage is not shortly followed by pick-up for installation, it is advisable to cover the packages with protective tarps.

To maintain original product performance, continuous indoor storage in ventilated facilities should not exceed six months, while outdoor storage should never exceed 60 days.

Packages stored at a height must always be properly bound to the structure.

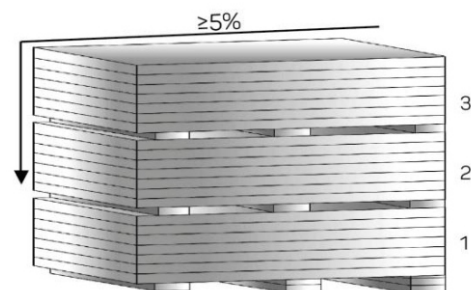

Figure 2

## PRE-PAINTED FACES

In case of prolonged storage, the pre-painted products must be stored indoors or under a canopy. There is the risk that stagnant humidity may attack the paint layer, causing it to detach from the galvanised support. It is not advisable to let more than two weeks elapse from when the products were stored at the site.



In case of container transport, the products must be removed from the container within 15 days from the loading date in order to prevent the metal supports from deteriorating.

**PANEL HANDLING**

The panels must be handled using adequate protection equipment (safety shoes, gloves, overalls, etc.) in compliance with current regulations.

The individual element must always be manually handled by lifting the element without dragging it on the ground and turning it sideways beside the package; it must be transported by at least two people according to the length, keeping the element on its side. (see Figure 3)

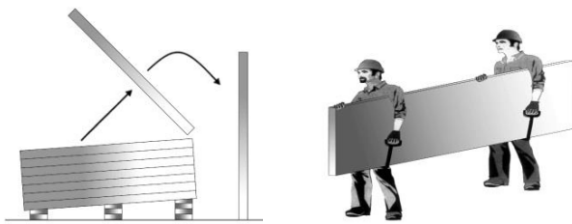

Figure 3  
Handling equipment as well as gloves must be clean and such as not to damage the items.

**INSTALLATION**

The panel installation personnel must be qualified and know the correct technique to perform the work in a workmanlike manner. If required, the seller can provide appropriate guidance and instructions.

The installation personnel must be equipped with footwear with soles that do not damage the external surface of the panel.

On-site cutting operations must be done with suitable tools (jigsaw, shears, nibbler, etc.).

We do not recommend using tools with abrasive discs.

To fasten the panels, it is advisable to use devices that can be provided by the seller.

Tighten the screws using a screwdriver with torque limitation.

For roofs with pitch elements without intermediate joints (overlaps), the slope should usually be no less than 7%. For slopes below that, the seller's requirements must be implemented.

In case of head overlaps, the slope should take into account the type of joint and material used, as well as the specific environmental conditions.

During panel assembly and, in particular, in roofs, it is necessary to immediately remove all residual materials paying special attention to metal ones that may cause early deterioration of the metal faces by oxidising.

**PROTECTIVE FILM**

The pre-painted metal facings are supplied upon request with adhesive polyethylene protective film that prevents damage to the paint layer.

The protective film covering the pre-painted panels must be completely removed during assembly or, in any case, within 60 days from material preparation.

It is also recommended not to expose the panels covered with protective film to direct sunlight.

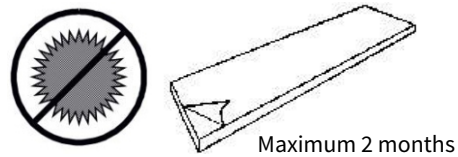

For the panels expressly requested without protective film, special care is required during handling on site and installation.

**MAINTENANCE**

The main routine maintenance operation is cleaning the panels. The panel surfaces that, following visual inspection, are found to be dirty or oxidised can be washed with soap and water using a soft brush. The cleaning water pressure can be applied up to 50 bar, but the jet must not be too close or perpendicular to the surfaces. Near the joints the water must be sprayed at a sufficient angle not to undermine their tightness.

YEARLY CHECKS OF THE ISOPAN PANELS	
WHAT TO INSPECT	CORRECTIVE ACTIONS
Conditions of the pre-painted surfaces (cracks and colour unevenness)	Assess the condition of the surfaces Repaint where possible
Scratches and dents	Repaint and repair dents
Fastening screws	Remove a screw and check if oxidised Tighten the screws where necessary
Angle parts of cut	Check the state of oxidation Clean and repaint

These provisions are taken from the General Conditions of Sale.

# Annex B

## SYMMETRICAL FASTENING HORIZONTAL PANEL INSTALLATION

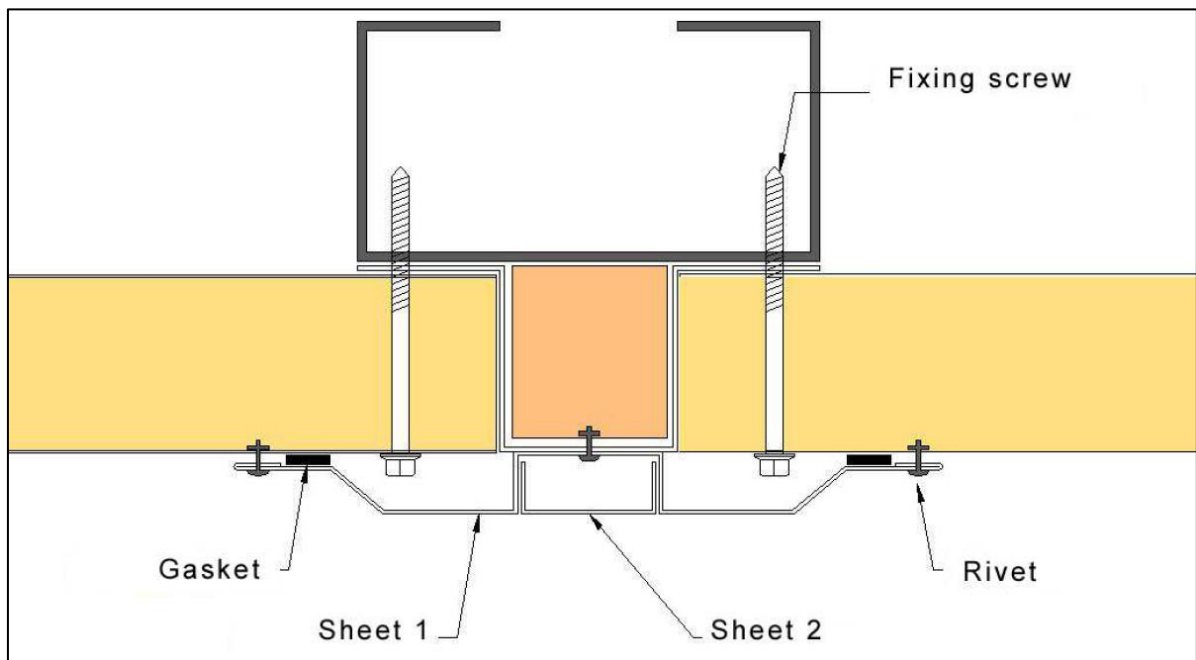
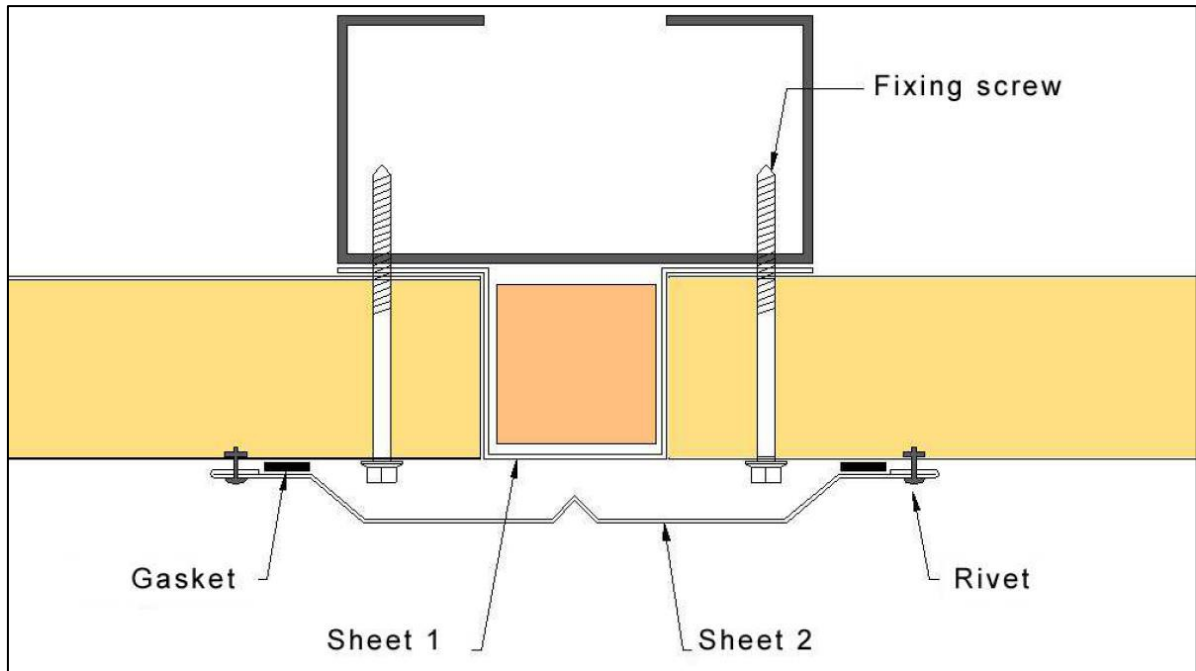

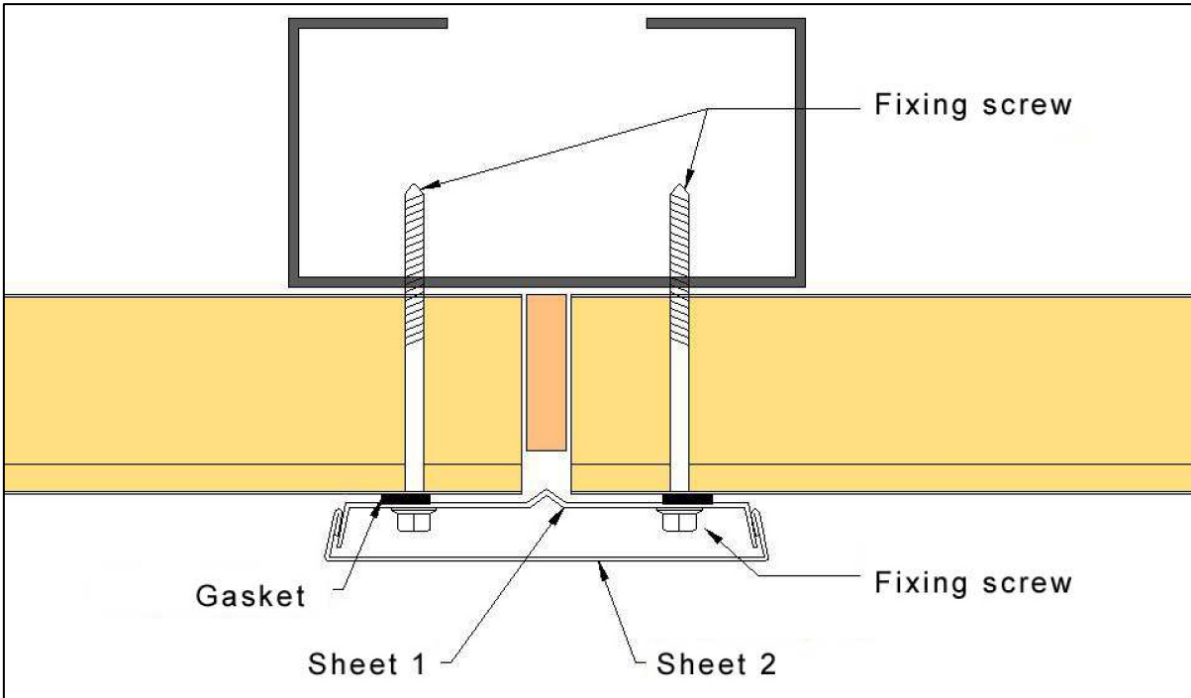
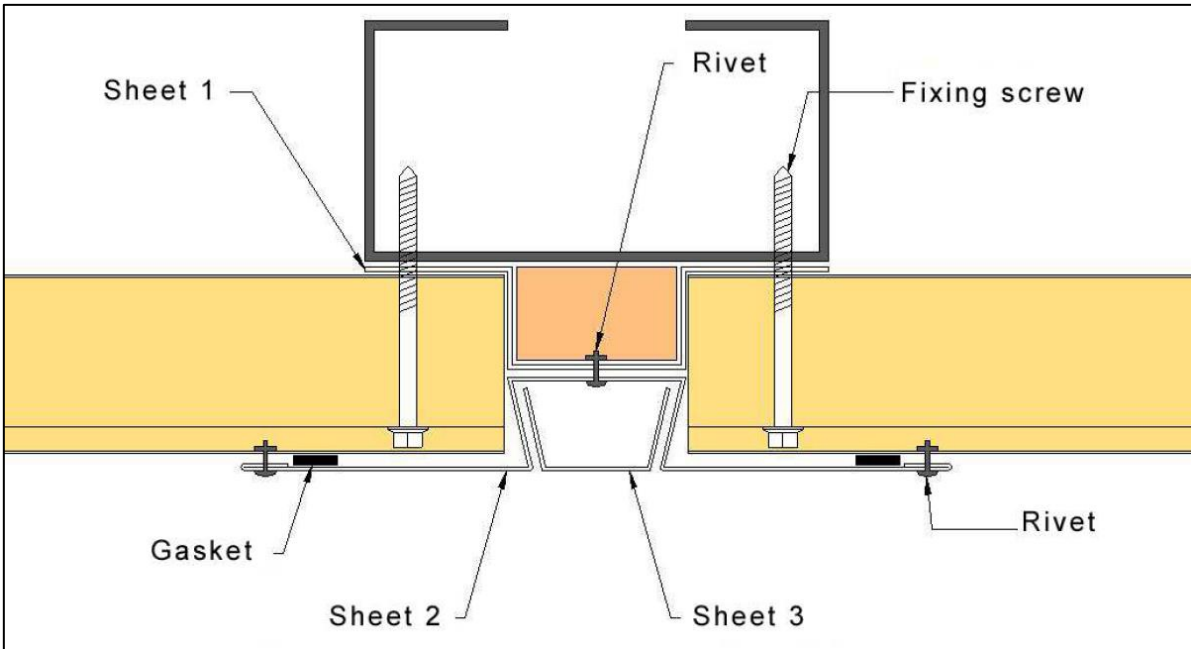

# Annex C

## INSTALLATION PHASES



The package containing the panels arrives at the construction site.

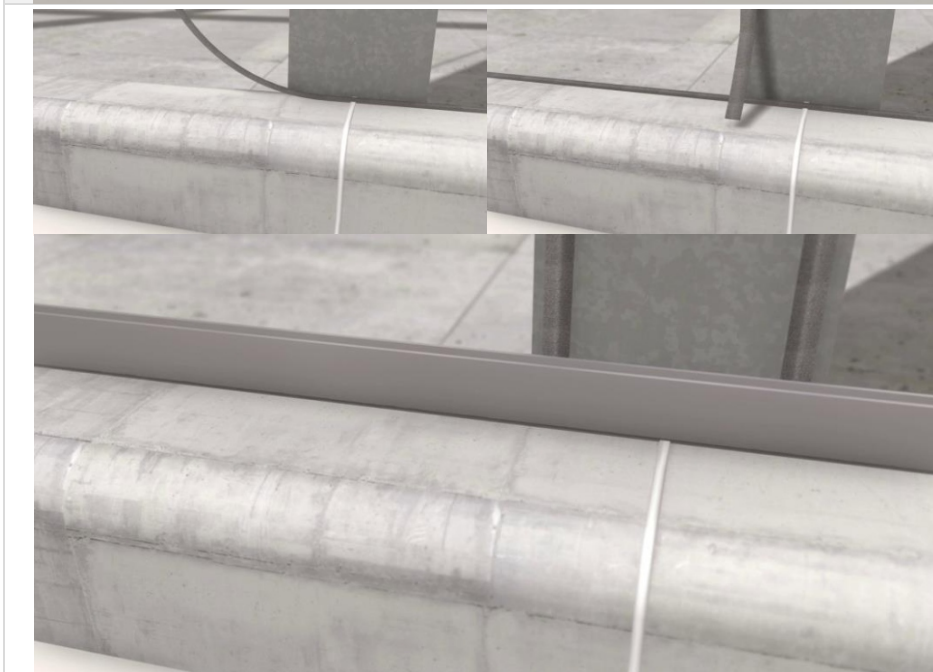



Position the watertight gaskets on the sub-structure as shown in the picture here and in the subsequent construction details (Annex D). Install the base support to apply the first panel.



**Handle the panel safely, as shown.**



**Once positioned, unhook the support straps in the lower part of the panel, then insert it carefully into the base support guide.**

	<p>Once in the correct position, fasten the upper part of the panel. Remember to use load spreading plates (the figure shows a single-hole solution that is not ideal for ISOWALL EVO panels).</p>
	<p>If necessary, intensify fastening by applying additional fasteners aligned with the previous one, as shown.</p>
	<p>Proceed in the same way as for the panels above.</p>



**When placing the adjacent panels, keep in mind the distance needed to insert the joint cover for the butt joint.**



**Once the panels are fastened, fill the butt joint space with insulating material without jeopardising the subsequent joint cover installation.**



**Install the joint cover and corresponding screw cover insert.**

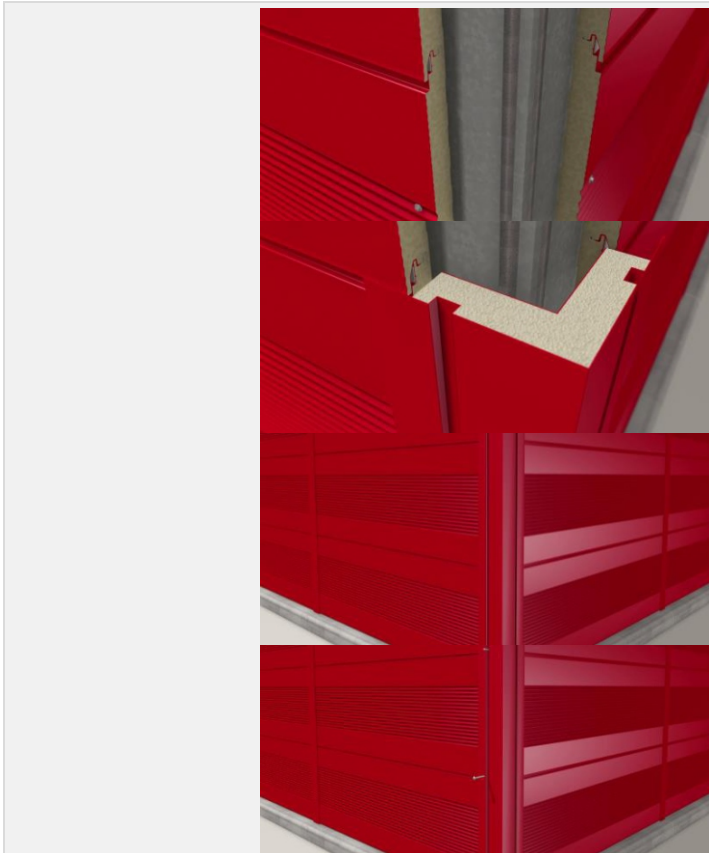

**For the corner sections, special, specifically made Insulating Angular Connections (RAC) may be installed.**



**Wall panel installation is complete.**

# Annex D

## VACUUM LIFTER

If the panels are handled with vacuum lifters, the operations must be performed avoiding stresses on the panel metal sheet. The action which performs the suction pad on the metal sheet during lifting must be redistributed properly taking into account the length and the weight of the panel itself.

To prevent excessive actions of the suction pads that could cause the detachment of the metal sheet from the insulating layer, Isopan recommends to observe the following restrictions:

### Polyurethane Panels:

Minimal surfaces for all the suction pads - Panels with Steel supports 0,4 / 0,4												
Panel length [mm]	Panel thickness [mm]											
	25	30	35	40	50	60	80	100	120	150	180	200
2000	340 cm2	350 cm2	350 cm2	360 cm2	380 cm2	390 cm2	430 cm2	460 cm2	490 cm2	540 cm2	590 cm2	620 cm2
3500	590 cm2	600 cm2	620 cm2	630 cm2	660 cm2	690 cm2	740 cm2	800 cm2	850 cm2	940 cm2	1.020 cm2	1.080 cm2
5000	840 cm2	860 cm2	880 cm2	900 cm2	940 cm2	980 cm2	1.060 cm2	1.140 cm2	1.220 cm2	1.340 cm2	1.460 cm2	1.540 cm2
6500	1.090 cm2	1.120 cm2	1.140 cm2	1.170 cm2	1.220 cm2	1.270 cm2	1.380 cm2	1.480 cm2	1.580 cm2	1.740 cm2	1.900 cm2	2.000 cm2
8000	1.340 cm2	1.370 cm2	1.400 cm2	1.440 cm2	1.500 cm2	1.560 cm2	1.690 cm2	1.820 cm2	1.950 cm2	2.140 cm2	2.330 cm2	2.460 cm2
10000	1.670 cm2	1.710 cm2	1.750 cm2	1.790 cm2	1.870 cm2	1.950 cm2	2.110 cm2	2.270 cm2	2.430 cm2	2.670 cm2	2.910 cm2	3.070 cm2
13000	2.170 cm2	2.230 cm2	2.280 cm2	2.330 cm2	2.430 cm2	2.540 cm2	2.750 cm2	2.950 cm2	3.160 cm2	3.470 cm2	3.790 cm2	3.990 cm2

Minimal surfaces for all the suction pads - Panels with Steel supports 0,6 / 0,6												
Panel length [mm]	Panel thickness [mm]											
	25	30	35	40	50	60	80	100	120	150	180	200
2000	490 cm2	490 cm2	500 cm2	510 cm2	530 cm2	540 cm2	570 cm2	610 cm2	640 cm2	690 cm2	730 cm2	770 cm2
3500	850 cm2	860 cm2	870 cm2	890 cm2	920 cm2	940 cm2	1.000 cm2	1.060 cm2	1.110 cm2	1.200 cm2	1.280 cm2	1.340 cm2
5000	1.210 cm2	1.230 cm2	1.250 cm2	1.270 cm2	1.310 cm2	1.350 cm2	1.430 cm2	1.510 cm2	1.590 cm2	1.710 cm2	1.830 cm2	1.910 cm2
6500	1.570 cm2	1.590 cm2	1.620 cm2	1.640 cm2	1.700 cm2	1.750 cm2	1.850 cm2	1.960 cm2	2.060 cm2	2.220 cm2	2.370 cm2	2.480 cm2
8000	1.930 cm2	1.960 cm2	1.990 cm2	2.020 cm2	2.090 cm2	2.150 cm2	2.280 cm2	2.410 cm2	2.530 cm2	2.730 cm2	2.920 cm2	3.050 cm2
10000	2.410 cm2	2.450 cm2	2.490 cm2	2.530 cm2	2.610 cm2	2.690 cm2	2.850 cm2	3.010 cm2	3.170 cm2	3.410 cm2	3.650 cm2	3.810 cm2
13000	3.130 cm2	3.180 cm2	3.230 cm2	3.280 cm2	3.390 cm2	3.490 cm2	3.700 cm2	3.910 cm2	4.120 cm2	4.430 cm2	4.740 cm2	4.950 cm2

Minimal surfaces for all the suction pads - Panels with Steel supports 0,8 / 0,8												
Panel length [mm]	Panel thickness [mm]											
	25	30	35	40	50	60	80	100	120	150	180	200
2000	630 cm2	640 cm2	650 cm2	660 cm2	670 cm2	690 cm2	720 cm2	750 cm2	780 cm2	830 cm2	880 cm2	910 cm2
3500	1.100 cm2	1.120 cm2	1.130 cm2	1.140 cm2	1.170 cm2	1.200 cm2	1.260 cm2	1.310 cm2	1.370 cm2	1.450 cm2	1.540 cm2	1.590 cm2
5000	1.570 cm2	1.590 cm2	1.610 cm2	1.630 cm2	1.670 cm2	1.710 cm2	1.790 cm2	1.870 cm2	1.950 cm2	2.070 cm2	2.190 cm2	2.270 cm2
6500	2.040 cm2	2.070 cm2	2.100 cm2	2.120 cm2	2.170 cm2	2.230 cm2	2.330 cm2	2.430 cm2	2.540 cm2	2.690 cm2	2.850 cm2	2.950 cm2
8000	2.510 cm2	2.550 cm2	2.580 cm2	2.610 cm2	2.670 cm2	2.740 cm2	2.870 cm2	2.990 cm2	3.120 cm2	3.310 cm2	3.510 cm2	3.630 cm2
10000	3.140 cm2	3.180 cm2	3.220 cm2	3.260 cm2	3.340 cm2	3.420 cm2	3.580 cm2	3.740 cm2	3.900 cm2	4.140 cm2	4.380 cm2	4.540 cm2
13000	4.080 cm2	4.130 cm2	4.190 cm2	4.240 cm2	4.340 cm2	4.450 cm2	4.650 cm2	4.860 cm2	5.070 cm2	5.380 cm2	5.690 cm2	5.900 cm2

**Mineral wool Panels:**

Minimal surfaces for all the suction pads - Panels with Steel supports 0,5 / 0,5							
Panel length [mm]	Panel thickness [mm]						
	50	60	80	100	120	150	200
<b>2000</b>	470 cm <sup>2</sup>	490 cm <sup>2</sup>	510 cm <sup>2</sup>	530 cm <sup>2</sup>	570 cm <sup>2</sup>	610 cm <sup>2</sup>	690 cm <sup>2</sup>
<b>3500</b>	820 cm <sup>2</sup>	860 cm <sup>2</sup>	890 cm <sup>2</sup>	930 cm <sup>2</sup>	1.000 cm <sup>2</sup>	1.070 cm <sup>2</sup>	1.210 cm <sup>2</sup>
<b>5000</b>	1.170 cm <sup>2</sup>	1.220 cm <sup>2</sup>	1.270 cm <sup>2</sup>	1.320 cm <sup>2</sup>	1.420 cm <sup>2</sup>	1.520 cm <sup>2</sup>	1.720 cm <sup>2</sup>
<b>6500</b>	1.520 cm <sup>2</sup>	1.590 cm <sup>2</sup>	1.650 cm <sup>2</sup>	1.720 cm <sup>2</sup>	1.850 cm <sup>2</sup>	1.980 cm <sup>2</sup>	2.240 cm <sup>2</sup>
<b>8000</b>	1.870 cm <sup>2</sup>	1.950 cm <sup>2</sup>	2.030 cm <sup>2</sup>	2.110 cm <sup>2</sup>	2.270 cm <sup>2</sup>	2.430 cm <sup>2</sup>	2.750 cm <sup>2</sup>
<b>10000</b>	2.340 cm <sup>2</sup>	2.440 cm <sup>2</sup>	2.540 cm <sup>2</sup>	2.640 cm <sup>2</sup>	2.840 cm <sup>2</sup>	3.040 cm <sup>2</sup>	3.440 cm <sup>2</sup>
<b>13000</b>	3.040 cm <sup>2</sup>	3.170 cm <sup>2</sup>	3.300 cm <sup>2</sup>	3.430 cm <sup>2</sup>	3.690 cm <sup>2</sup>	3.950 cm <sup>2</sup>	4.470 cm <sup>2</sup>

Minimal surfaces for all the suction pads - Panels with Steel supports 0,8 / 0,8							
Panel length [mm]	Panel thickness [mm]						
	50	60	80	100	120	150	200
<b>2000</b>	690 cm <sup>2</sup>	710 cm <sup>2</sup>	730 cm <sup>2</sup>	750 cm <sup>2</sup>	790 cm <sup>2</sup>	830 cm <sup>2</sup>	910 cm <sup>2</sup>
<b>3500</b>	1.210 cm <sup>2</sup>	1.240 cm <sup>2</sup>	1.280 cm <sup>2</sup>	1.310 cm <sup>2</sup>	1.380 cm <sup>2</sup>	1.450 cm <sup>2</sup>	1.590 cm <sup>2</sup>
<b>5000</b>	1.720 cm <sup>2</sup>	1.770 cm <sup>2</sup>	1.820 cm <sup>2</sup>	1.870 cm <sup>2</sup>	1.970 cm <sup>2</sup>	2.070 cm <sup>2</sup>	2.270 cm <sup>2</sup>
<b>6500</b>	2.240 cm <sup>2</sup>	2.300 cm <sup>2</sup>	2.370 cm <sup>2</sup>	2.430 cm <sup>2</sup>	2.560 cm <sup>2</sup>	2.690 cm <sup>2</sup>	2.950 cm <sup>2</sup>
<b>8000</b>	2.750 cm <sup>2</sup>	2.830 cm <sup>2</sup>	2.910 cm <sup>2</sup>	2.990 cm <sup>2</sup>	3.150 cm <sup>2</sup>	3.310 cm <sup>2</sup>	3.630 cm <sup>2</sup>
<b>10000</b>	3.440 cm <sup>2</sup>	3.540 cm <sup>2</sup>	3.640 cm <sup>2</sup>	3.740 cm <sup>2</sup>	3.940 cm <sup>2</sup>	4.140 cm <sup>2</sup>	4.540 cm <sup>2</sup>
<b>13000</b>	4.470 cm <sup>2</sup>	4.600 cm <sup>2</sup>	4.730 cm <sup>2</sup>	4.860 cm <sup>2</sup>	5.120 cm <sup>2</sup>	5.380 cm <sup>2</sup>	5.900 cm <sup>2</sup>

**N.B. : Thicknesses that are not listed in the tables can be interpolated linearly.**

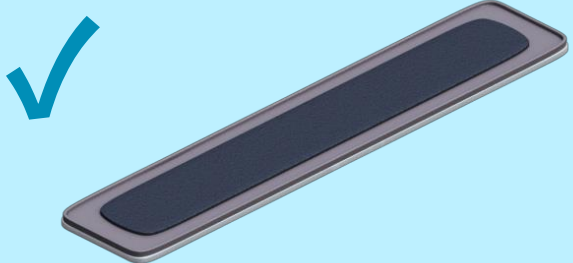
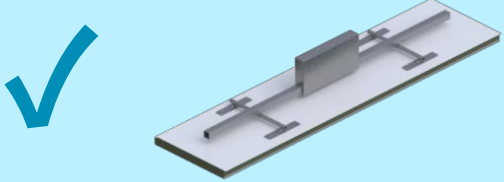
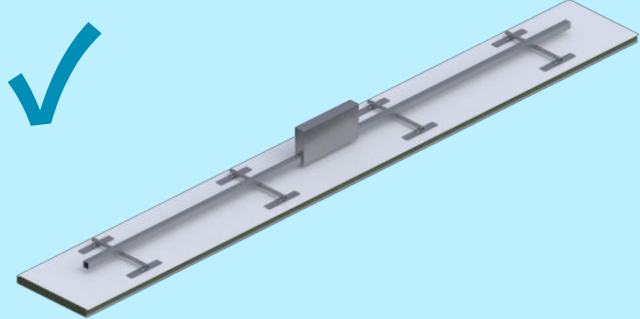
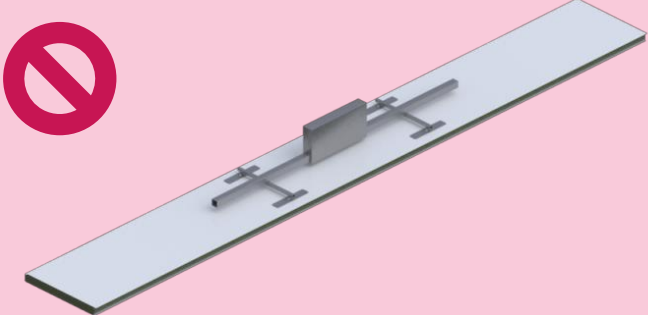
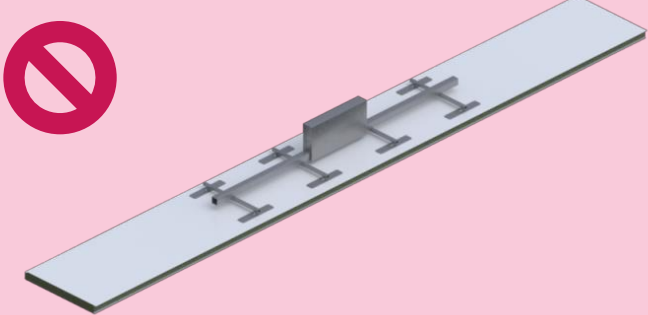
<p><b>TO ENSURE THE FLATNESS OF THE METAL SHEET DURING THE AIR INTAKE YOU MUST PUT IN THE SUCTION PADS AN APPROPRIATE BUFFER STIFFENING</b></p>	
<p><b>AT LEAST 4 SUCTION PADS EQUALLY DISTRIBUTED FOR PANEL LENGTHS LOWER THAN 6 METERS</b></p>	
<p><b>AT LEAST 8 SUCTION PADS EQUALLY DISTRIBUTED FOR PANEL LENGTHS HIGHER THAN 6 METERS</b></p>	
<p><b>NOT ENOUGH SUCTION PADS</b></p>	
<p><b>SUCTION PADS NOT EQUALLY DISTRIBUTED</b></p>	

# Annex E

## **BUILDING DETAILS**

*RAO 06 - Inner wall corner connection*

*RAO 07 - Wall corner connection*

*RPCV 13 - Flat roof wall connection*

*RPCV 14 - Roof wall connection with insulated gutter with parapet*

*RPCV 03 - Roof wall connection with gutter*

*RPCV 04 - Roof wall connection with single roof pitch ridge*

*RPCV 32 - Roof wall connection with insulated gutter*

*SPO 11 - Horizontal butt joint (flat solution)*

*SPO 13 - Horizontal butt joint (thickness solution)*

*SPO 15 - Horizontal butt joint (for thermal expansion)*

*SCV 04 - Concrete base kerb wall panel connection*

*SCV 22 - Vertical butt joint*

**The solutions shown on the following pages can be made with ISOPARETE PLISSÈ panels but are to be considered conceptually valid also for ISOPARETE EVO and ISOPARETE PLUS type panels, as they have the same "concealed" fastening system in common.**

**INNER WALL CORNER CONNECTION**

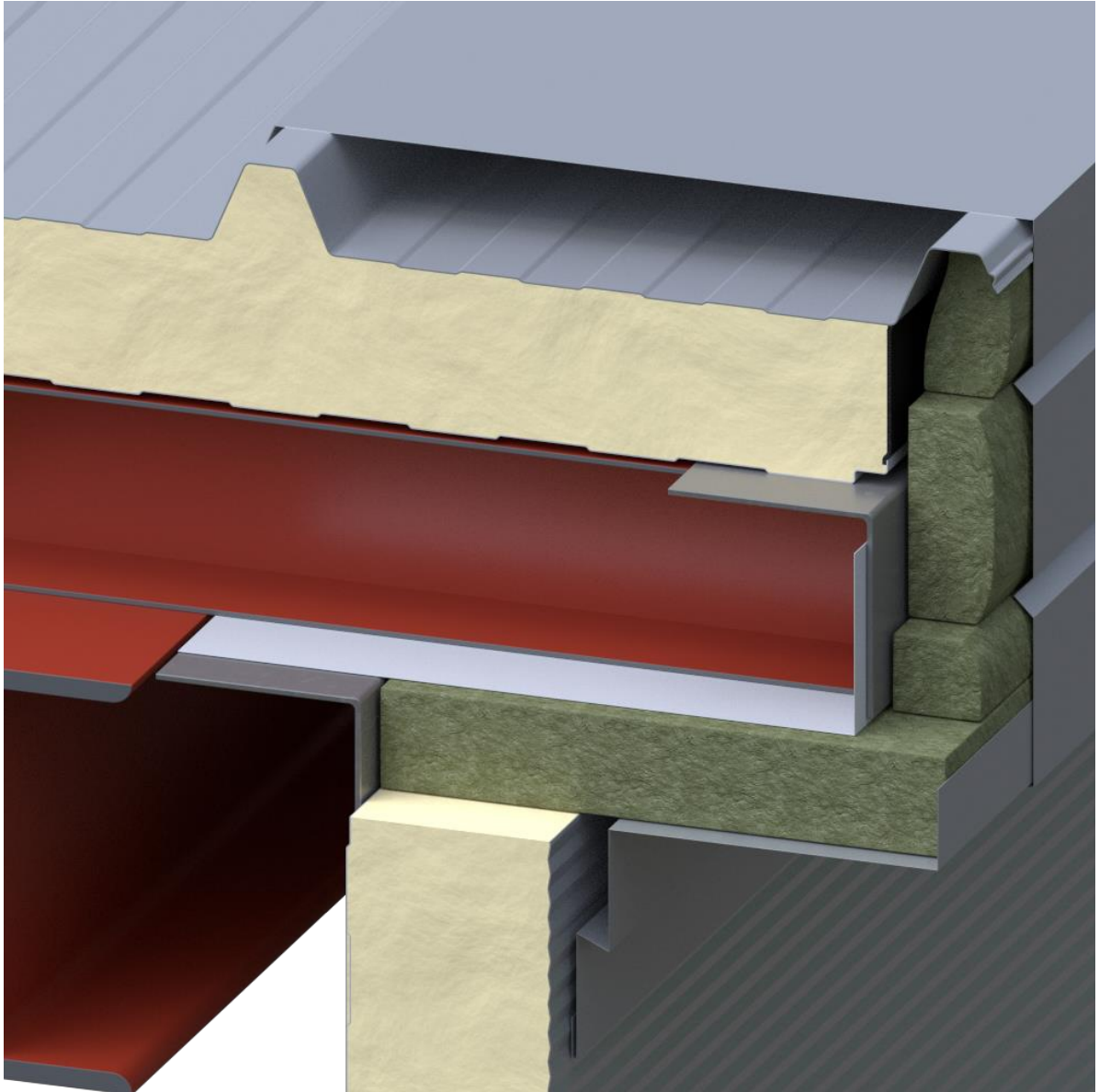

RPCV 13mp

Unión lateral pared cubierta

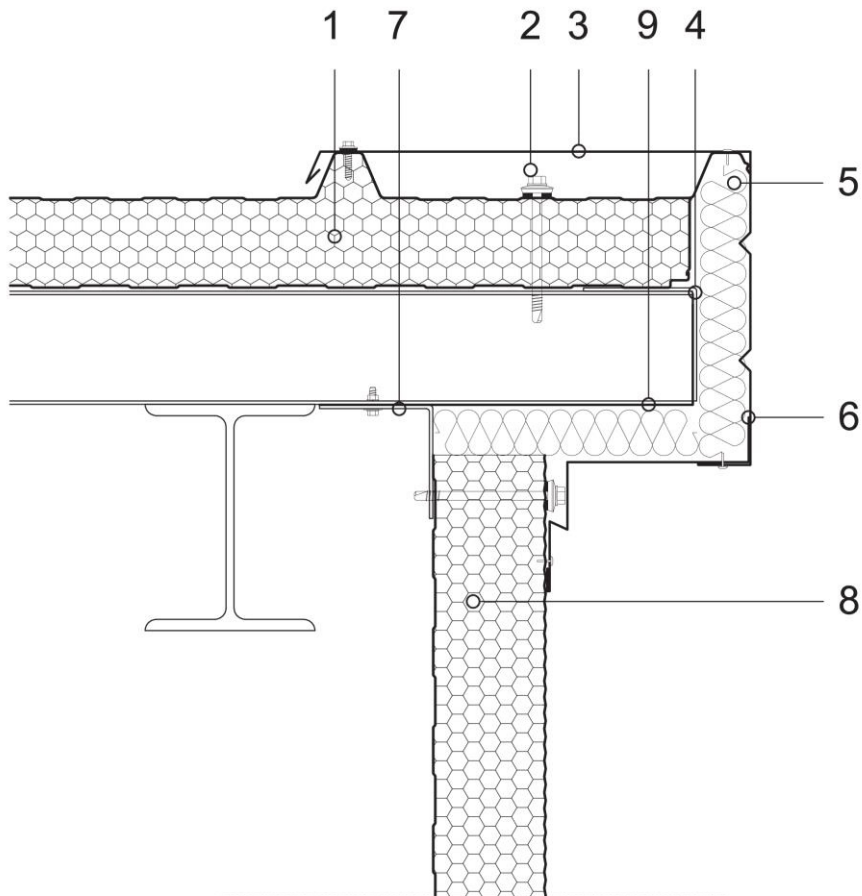

Es tarea del proyectista evaluar la necesidad de introducir otros elementos de guarnición y/o cierre, incluso cuando no se detallan en el dibujo.

Leyenda

1	Panel de cubierta IsoCindu
2	Tornillo de fijación del panel de cubierta
3	Moldura de protección
4	Moldura de cierre en L
5	Aislante de lana mineral
6	Moldura de protección
7	Moldura de cierre interna
8	Panel de pared IsoCindu
9	Moldura de cierre en L

ATENCIÓN: la solución propuesta no constituye un proyecto, y debe ser examinada y evaluada preventivamente por el proyectista o por la dirección de obra. El presente tratado es propiedad exclusiva de ISOPAN S.p.A. y se prohíbe la reproducción, incluso parcial, de los contenidos sin la autorización escrita del autor. Para la elección del tipo de fijación, remítase a la ficha para la selección del tipo de tornillo; para la elección de la longitud del tornillo, remítase a la ficha para la correcta longitud del tornillo.

**WALL CORNER CONNECTION**

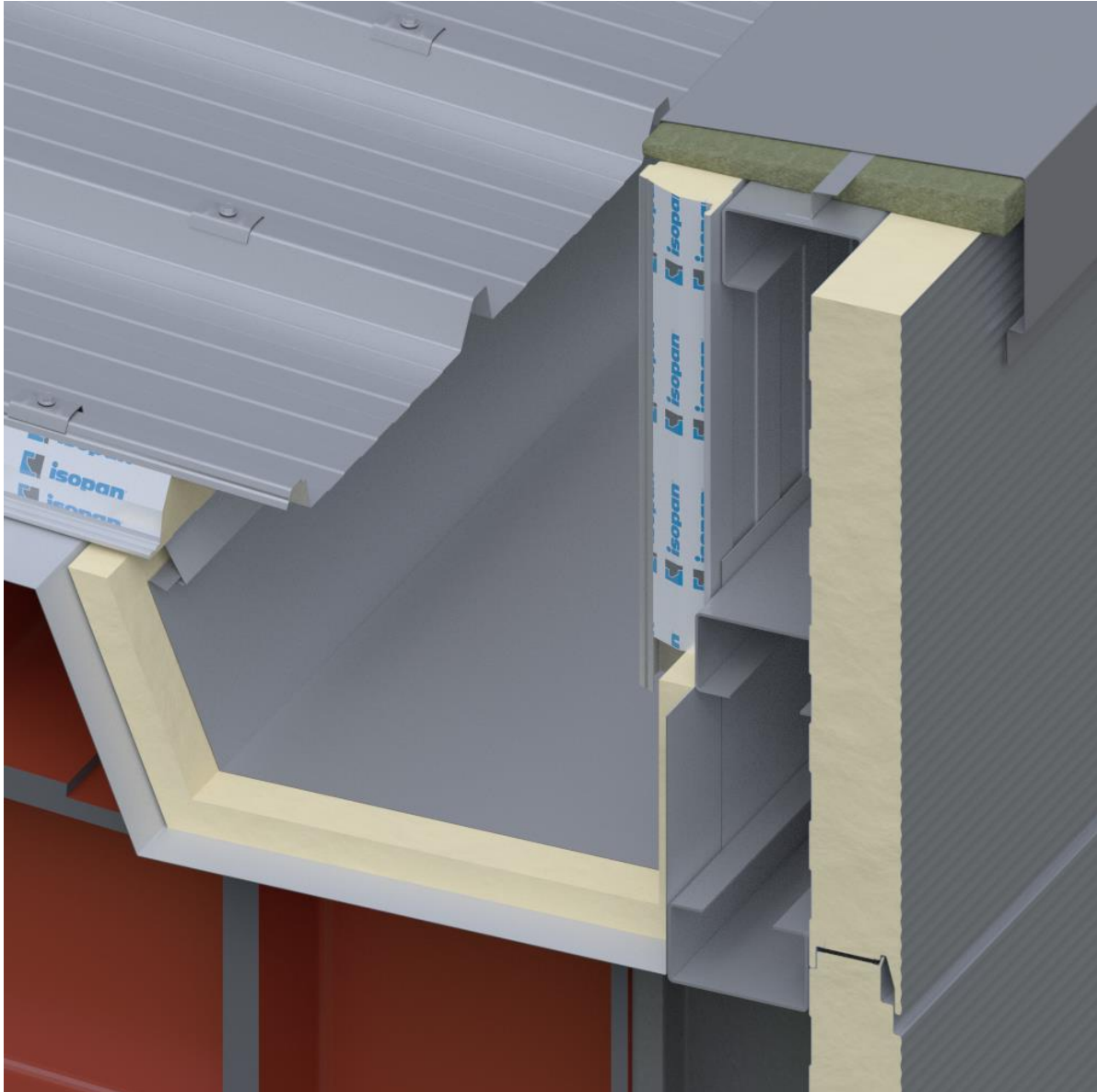

Racor pared cubierta con canalón aislado tipo 4

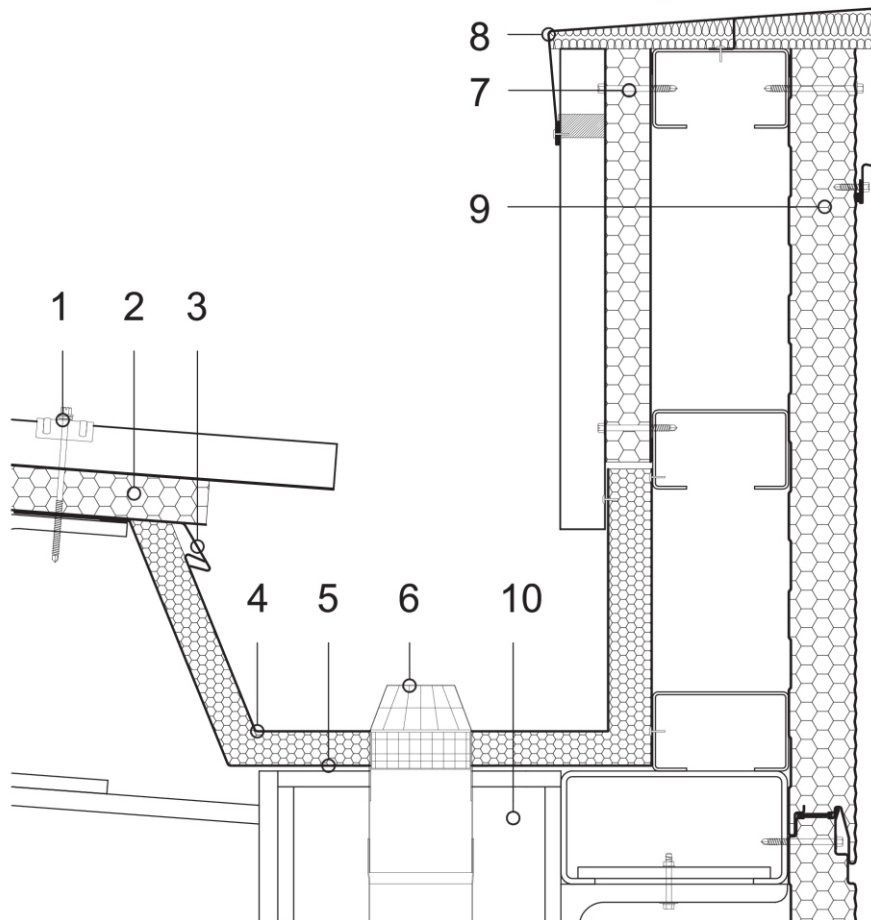

Es tarea del proyectista evaluar la necesidad de introducir otros elementos de guarnición y/o cierre, incluso cuando no se detallan en el dibujo.

Leyenda

1	Grupo de fijación del panel de cubierta
2	Panel de cubierta IsoCindu
3	Moldura goterón
4	Moldura de canalón
5	Moldura canalón interno
6	Rejilla para hojas
7	Tornillo de fijación pasante
8	Moldura de protección parapeto
9	Panel de pared IsoCindu
10	Estructura principal de acero

ATENCIÓN: la solución propuesta no constituye un proyecto, y debe ser examinada y evaluada preventivamente por el proyectista o por la dirección de obra. El presente tratado es propiedad exclusiva de ISOPAN S.p.A. y se prohíbe la reproducción, incluso parcial, de los contenidos sin la autorización escrita del autor. Para la elección del tipo de fijación, remítase a la ficha para la selección del tipo de tornillo; para la elección de la longitud del tornillo, remítase a la ficha para la correcta longitud del tornillo.

**FLAT ROOF WALL CONNECTION**

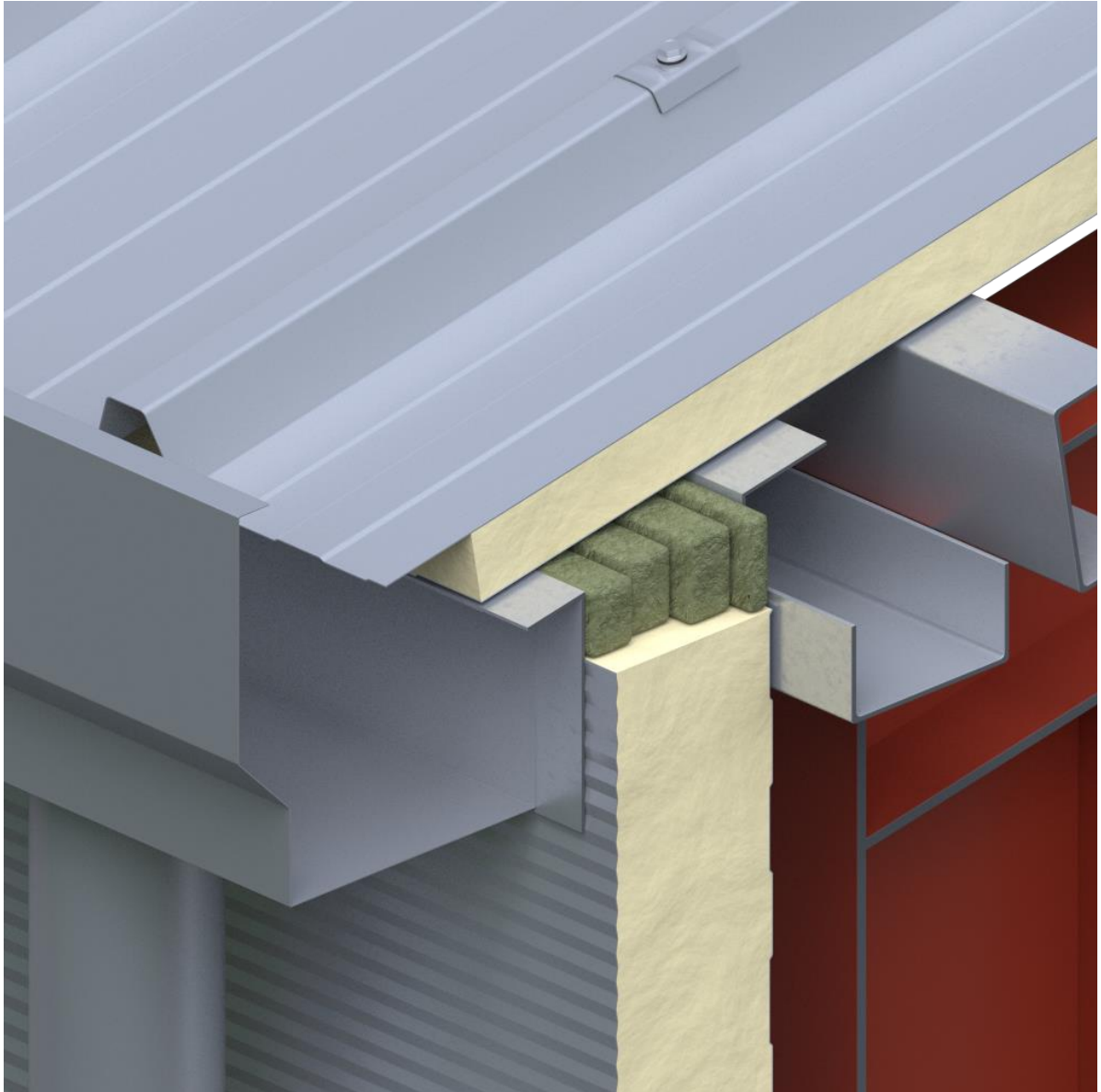

## Unión pared cubierta con canalón tipo 1

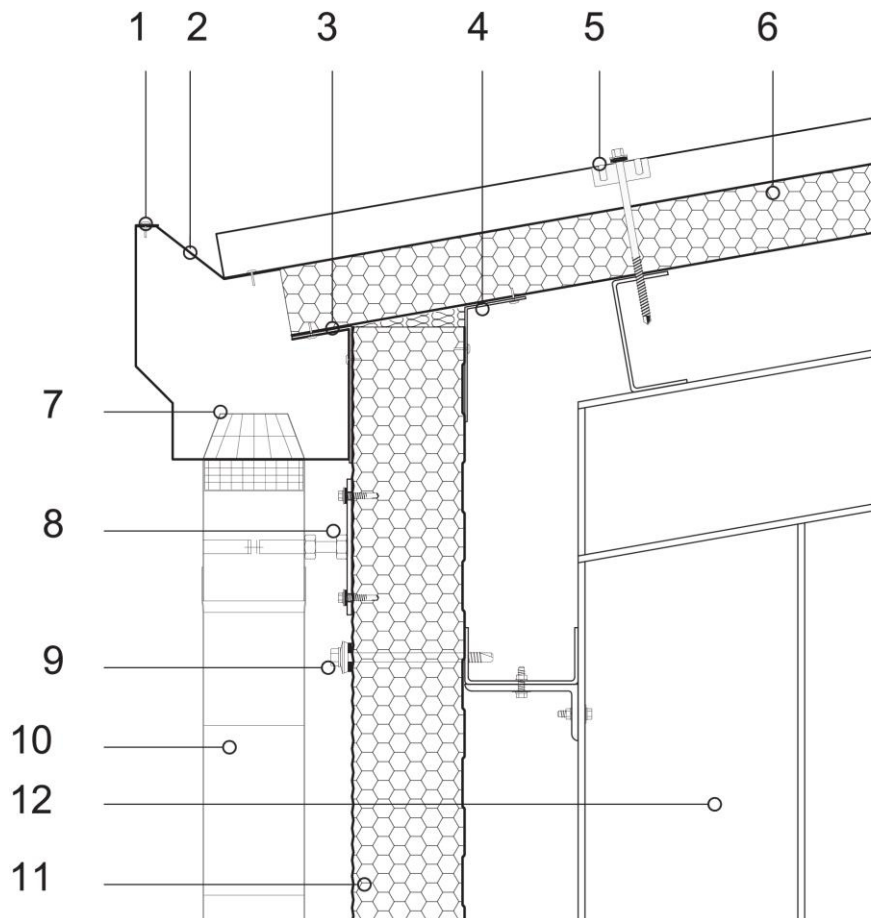

Es tarea del proyectista evaluar la necesidad de introducir otros elementos de guarnición y/o cierre, incluso cuando no se detallan en el dibujo.

## Leyenda

1	Remache	11	Panel de pared IsoCindu
2	Moldura de sostén canalón	12	Estructura principal
3	Moldura angular de cierre externo		
4	Moldura angular de cierre Interno		
5	Grupo de fijación del panel de cubierta		
6	Panel de cubierta IsoCindu		
7	Rejilla para hojas		
8	Grupo de fijación del canalón		
9	Tornillo de fijación pasante		
10	Canalón		

ATENCIÓN: la solución propuesta no constituye un proyecto, y debe ser examinada y evaluada preventivamente por el proyectista o por la dirección de obra. El presente tratado es propiedad exclusiva de ISOPAN S.p.A. y se prohíbe la reproducción, incluso parcial, de los contenidos sin la autorización escrita del autor. Para la elección del tipo de fijación, remítase a la ficha para la selección del tipo de tornillo; para la elección de la longitud del tornillo, remítase a la ficha para la correcta longitud del tornillo.

**ROOF WALL CONNECTION WITH INSULATED GUTTER WITH PARAPET**

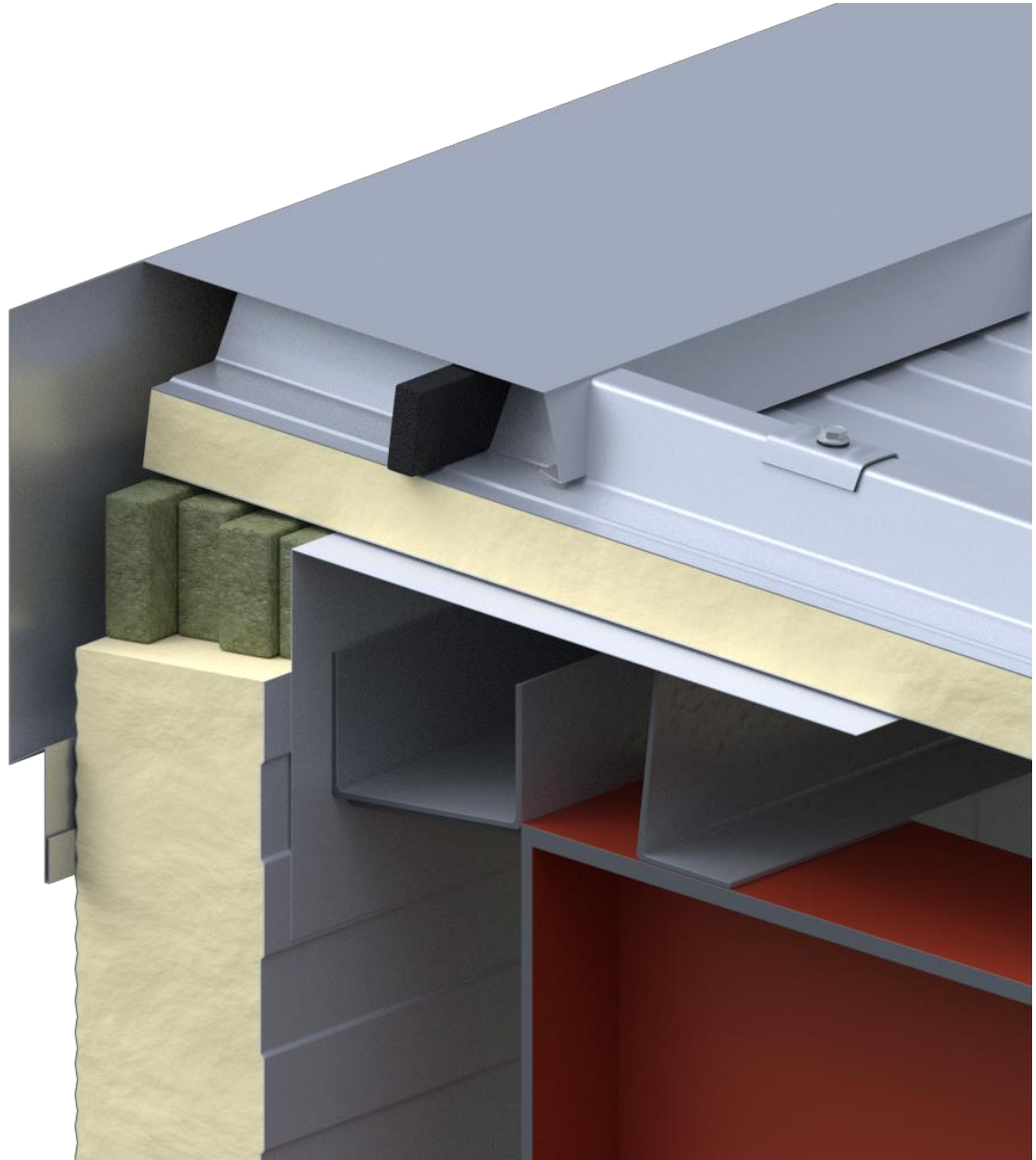

Unión pared cubierta tipo 1

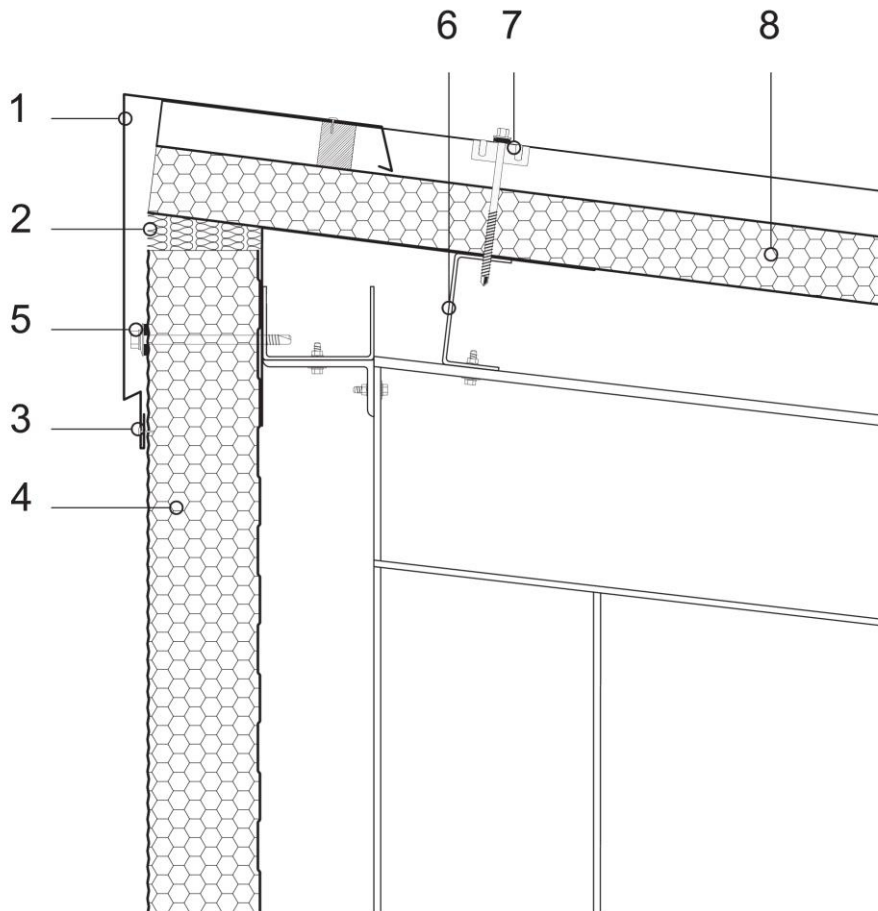

Es tarea del proyectista evaluar la necesidad de introducir otros elementos de guarnición y/o cierre, incluso cuando no se detallan en el dibujo.

Leyenda

1	Moldura de cierre
2	Aislante de espuma de poliuretano
3	Remache
4	Panel de pared IsoCindu
5	Tornillo de fijación pasante
6	Estructura de acero secundaria
7	Tornillo de fijación pasante cubierta - moldura
8	Panel de cubierta IsoCindu

ATENCIÓN: la solución propuesta no constituye un proyecto, y debe ser examinada y evaluada preventivamente por el proyectista o por la dirección de obra. El presente tratado es propiedad exclusiva de ISOPAN S.p.A. y se prohíbe la reproducción, incluso parcial, de los contenidos sin la autorización escrita del autor. Para la elección del tipo de fijación, remítase a la ficha para la selección del tipo de tornillo; para la elección de la longitud del tornillo, remítase a la ficha para la correcta longitud del tornillo.

**ROOF WALL CONNECTION WITH GUTTER**

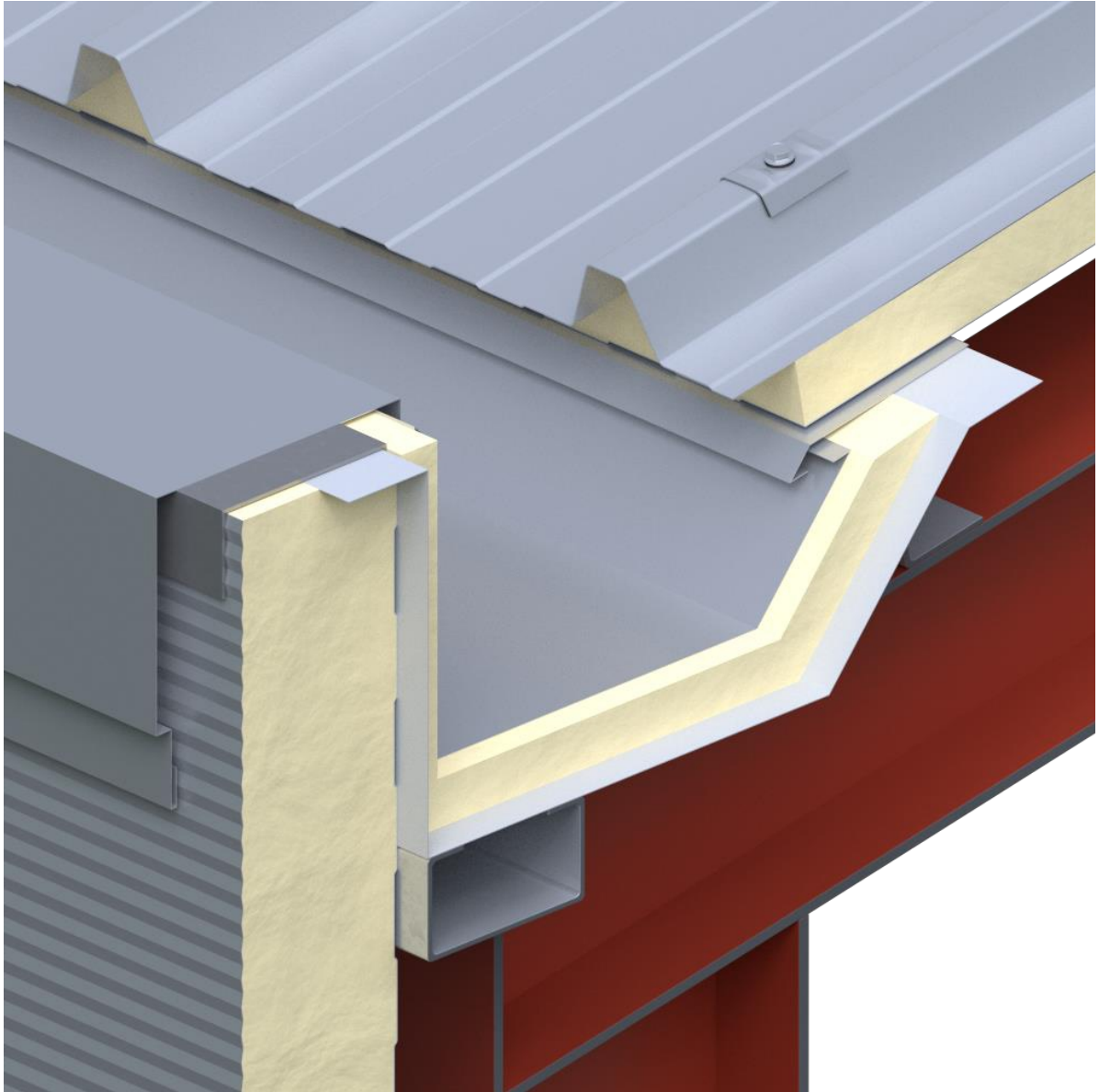

Unión pared cubierta con canalón aislado

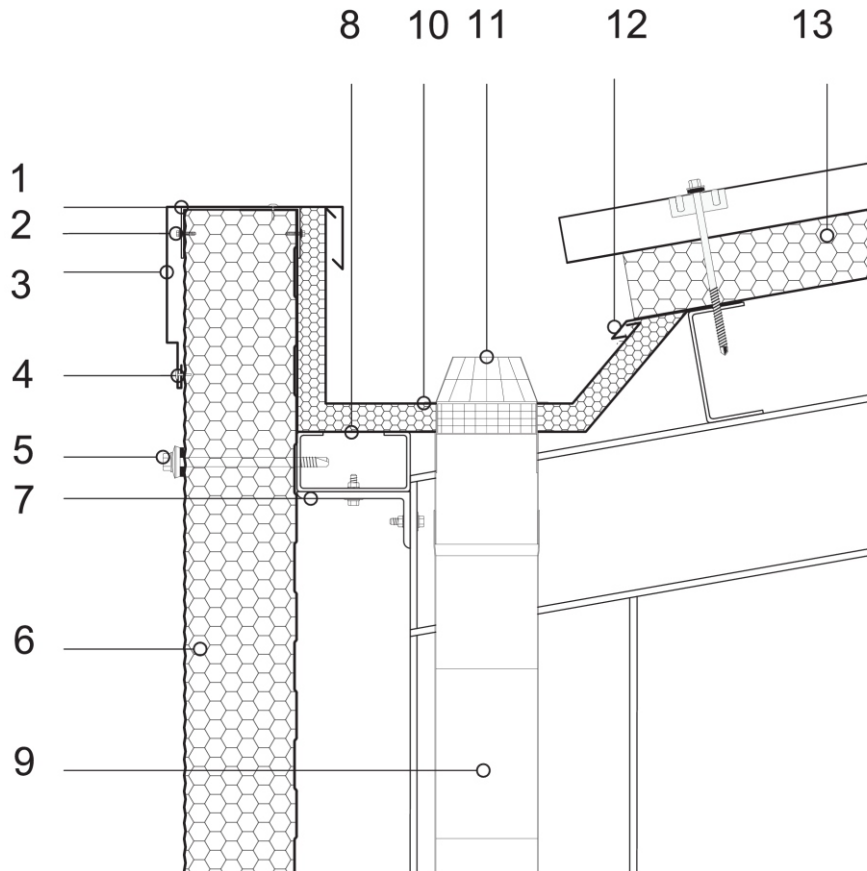

Es tarea del proyectista evaluar la necesidad de introducir otros elementos de guarnición y/o cierre, incluso cuando no se detallan en el dibujo.

Leyenda

1	Moldura cierre extremo superior	11	Rejilla para hojas
2	Tornillo de fijación	12	Moldura goterón
3	Moldura de protección	13	Panel de cubierta IsoCindu
4	Remache		
5	Tornillo de fijación pasante		
6	Panel de pared IsoCindu		
7	Estructura portante de acero		
8	Molduracanalón interno		
9	Pluvial		
10	Canalón		

ATENCIÓN: la solución propuesta no constituye un proyecto, y debe ser examinada y evaluada preventivamente por el proyectista o por la dirección de obra. El presente tratado es propiedad exclusiva de ISOPAN S.p.A. y se prohíbe la reproducción, incluso parcial, de los contenidos sin la autorización escrita del autor. Para la elección del tipo de fijación, remítase a la ficha para la selección del tipo de tornillo; para la elección de la longitud del tornillo, remítase a la ficha para la correcta longitud del tornillo.

**ROOF WALL CONNECTION WITH SINGLE ROOF PITCH RIDGE**

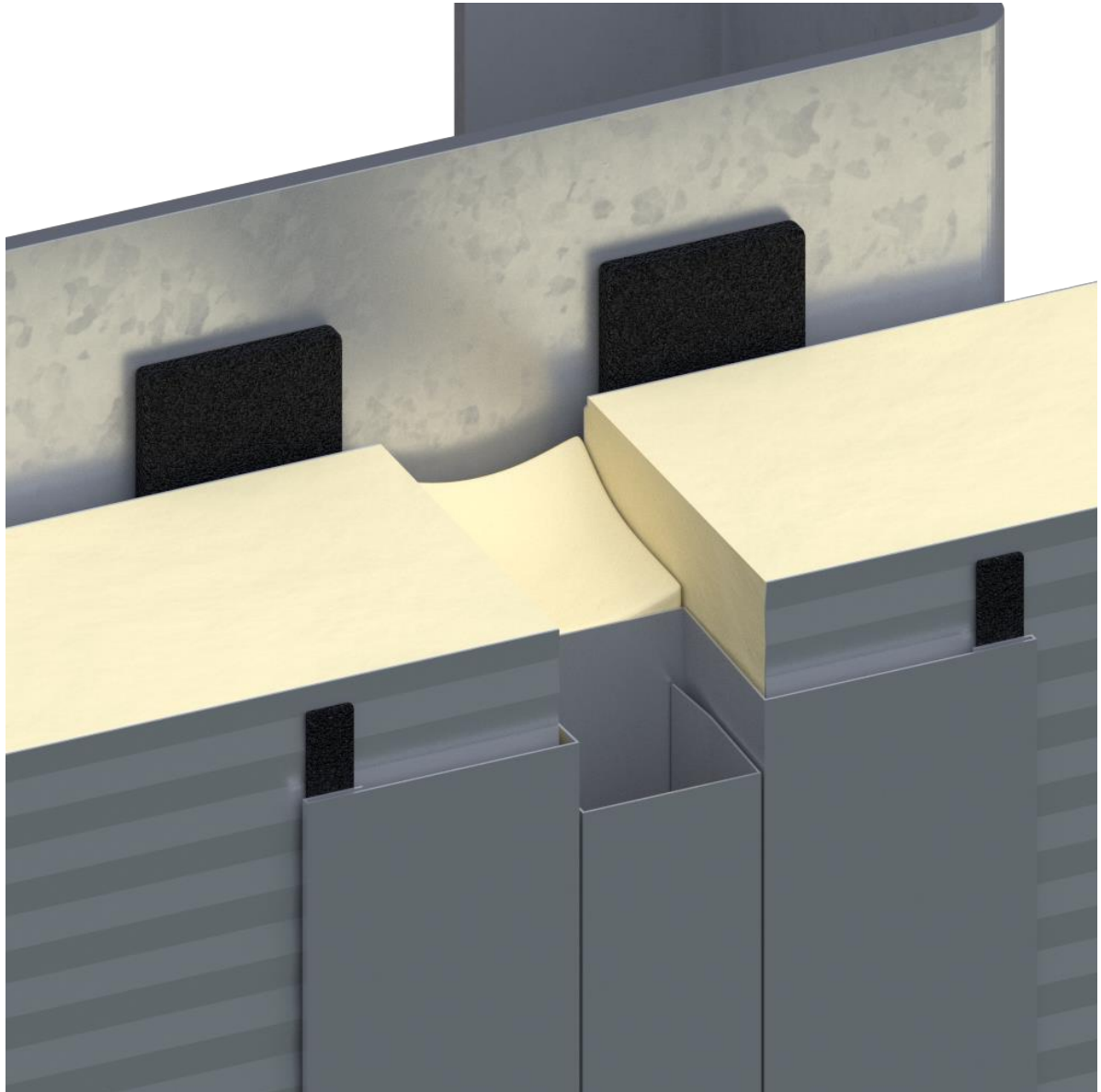

## SPO 11

### Solape horizontal entre los paneles de pared tipo 1

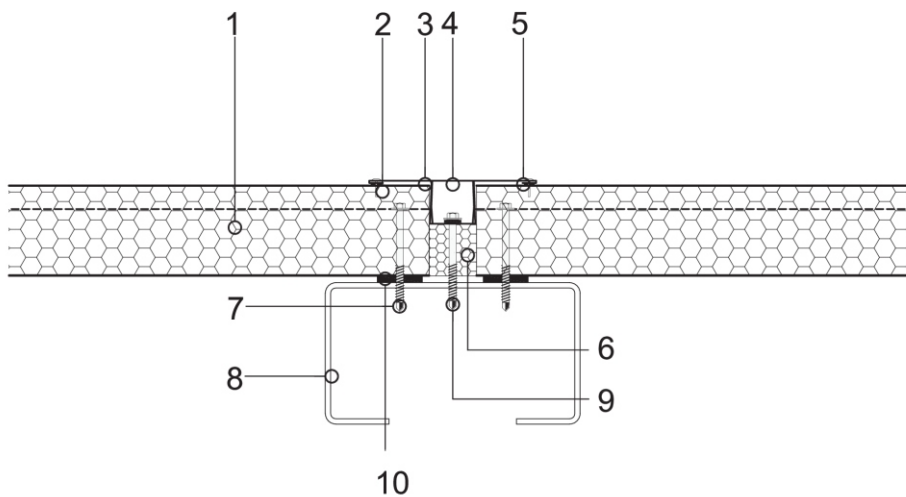

Es tarea del proyectista evaluar la necesidad de introducir otros elementos de guarnición y/o cierre, incluso cuando no se detallan en el dibujo.

#### Leyenda

1	Panel de pared con fijación escondida IsoCindu
2	Junta de goma EPDM
3	Moldura de unión junta
4	Moldura de cubierta tornillo
5	Remache
6	Aislante de espuma de poliuretano
7	Tornillo de fijación del panel
8	Soporte de acero
9	Tornillo de fijación moldura
10	Junta de goma EPDM

ATENCIÓN: la solución propuesta no constituye un proyecto, y debe ser examinada y evaluada preventivamente por el proyectista o por la dirección de obra. El presente tratado es propiedad exclusiva de ISOPAN S.p.A. y se prohíbe la reproducción, incluso parcial, de los contenidos sin la autorización escrita del autor. Para la elección del tipo de fijación, remítase a la ficha para la selección del tipo de tornillo; para la elección de la longitud del tornillo, remítase a la ficha para la correcta longitud del tornillo.

**ROOF WALL CONNECTION WITH INSULATED GUTTER**

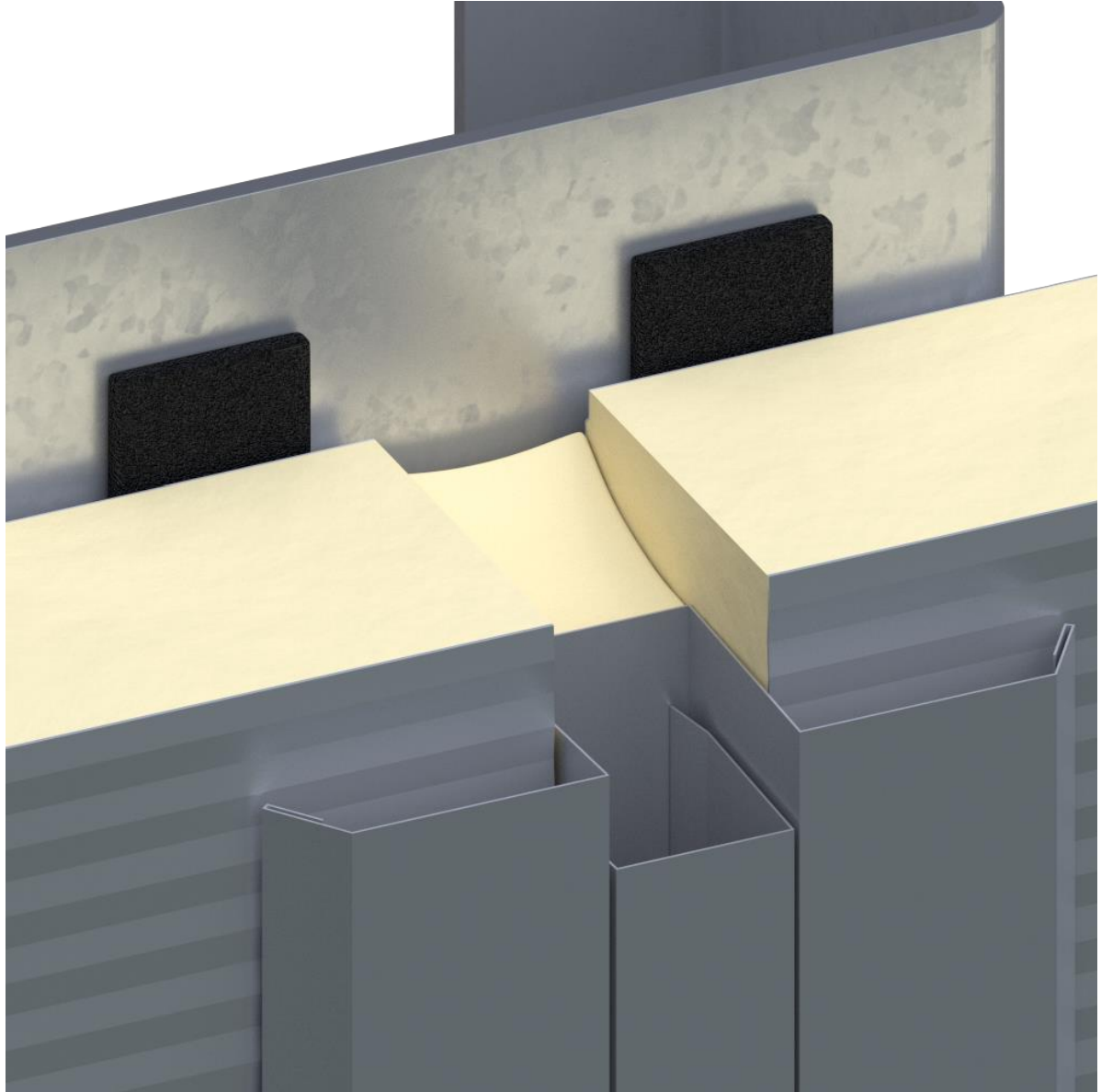

## SPO 13

### Solape horizontal entre los paneles de pared tipo 3

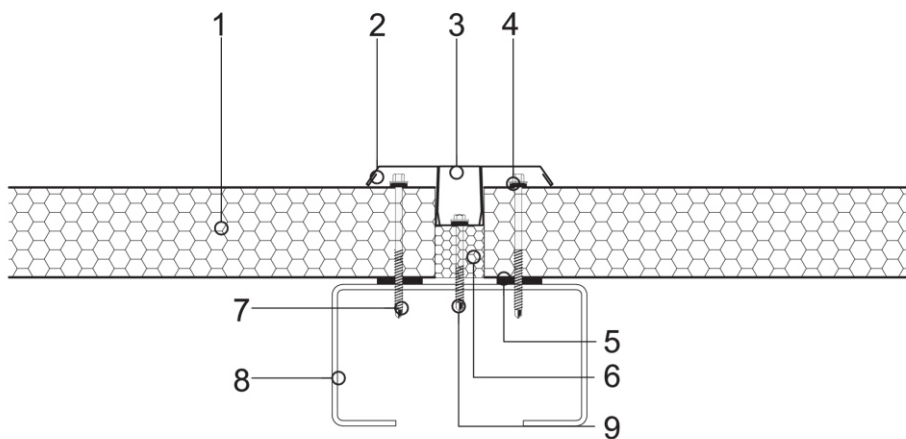

Es tarea del proyectista evaluar la necesidad de introducir otros elementos de guarnición y/o cierre, incluso cuando no se detallan en el dibujo.

#### Leyenda

1	Panel de pared IsoCindu
2	Moldura de unión junta
3	Moldura de cubierta tornillo
4	Remache
5	Junta de goma EPDM
6	Aislante de espuma de poliuretano
7	Tornillo de fijación del panel
8	Soporte de acero
9	Tornillo de ijación moldura

ATENCIÓN: la solución propuesta no constituye un proyecto, y debe ser examinada y evaluada preventivamente por el proyectista o por la dirección de obra. El presente tratado es propiedad exclusiva de ISOPAN S.p.A. y se prohíbe la reproducción, incluso parcial, de los contenidos sin la autorización escrita del autor. Para la elección del tipo de fijación, remitase a la ficha para la selección del tipo de tornillo; para la elección de la longitud del tornillo, remitase a la ficha para la correcta longitud del tornillo.

**HORIZONTAL BUTT JOINT (FLAT SOLUTION)**

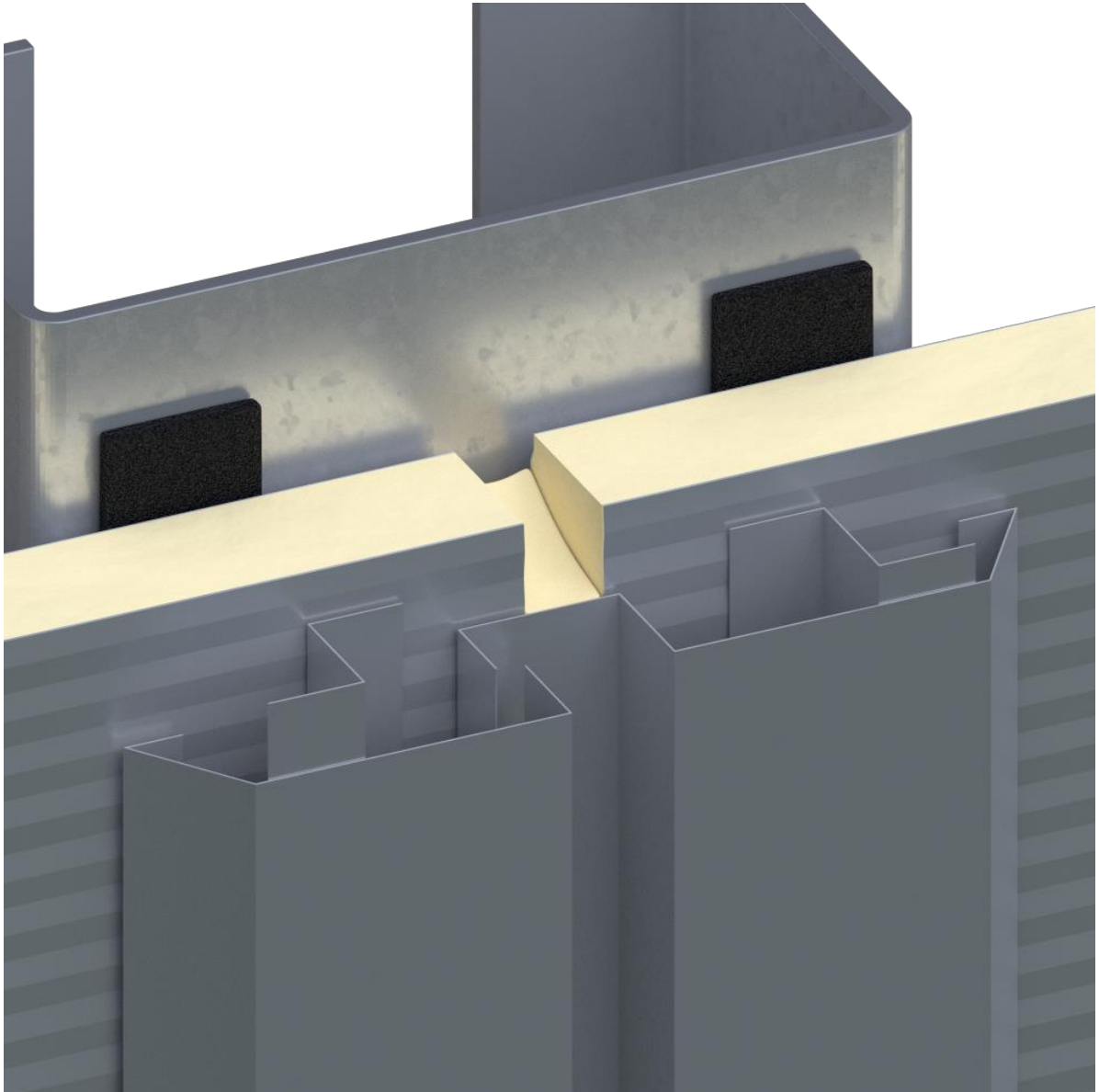

## SPO 15

### Solape horizontal entre los paneles de pared tipo 5

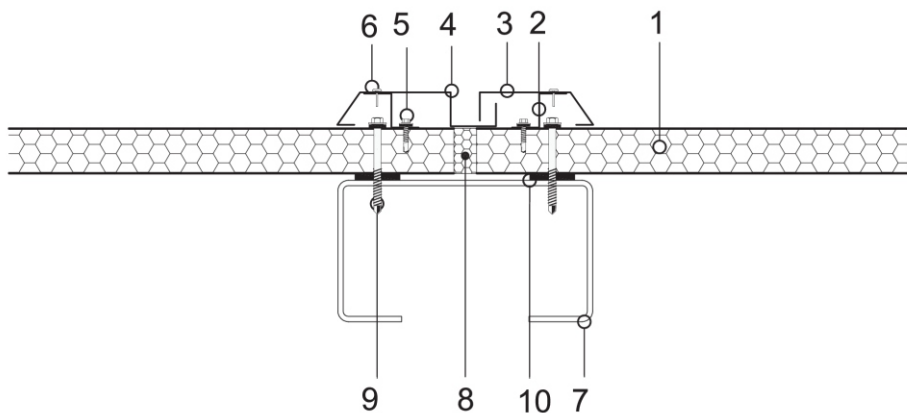

Es tarea del proyectista evaluar la necesidad de introducir otros elementos de guarnición y/o cierre, incluso cuando no se detallan en el dibujo.

#### Leyenda

1	Panel de pared IsoCindu
2	Moldura de sostén
3	Moldura de racor junta
4	Moldura de racor junta
5	Tomillo de fijación chapa
6	Remache
7	Soporte de acero
8	Aislante de espuma de poliuretano
9	Tomillo de fijación panel
10	Junta de goma EPDM

ATENCIÓN: la solución propuesta no constituye un proyecto, y debe ser examinada y evaluada preventivamente por el proyectista o por la dirección de obra. El presente tratado es propiedad exclusiva de ISOPAN S.p.A. y se prohíbe la reproducción, incluso parcial, de los contenidos sin la autorización escrita del autor. Para la elección del tipo de fijación, remítase a la ficha para la selección del tipo de tomillo; para la elección de la longitud del tomillo, remítase a la ficha para la correcta longitud del tomillo.

**WALL PANEL TO CONCRETE BASE KERB CONNECTION**

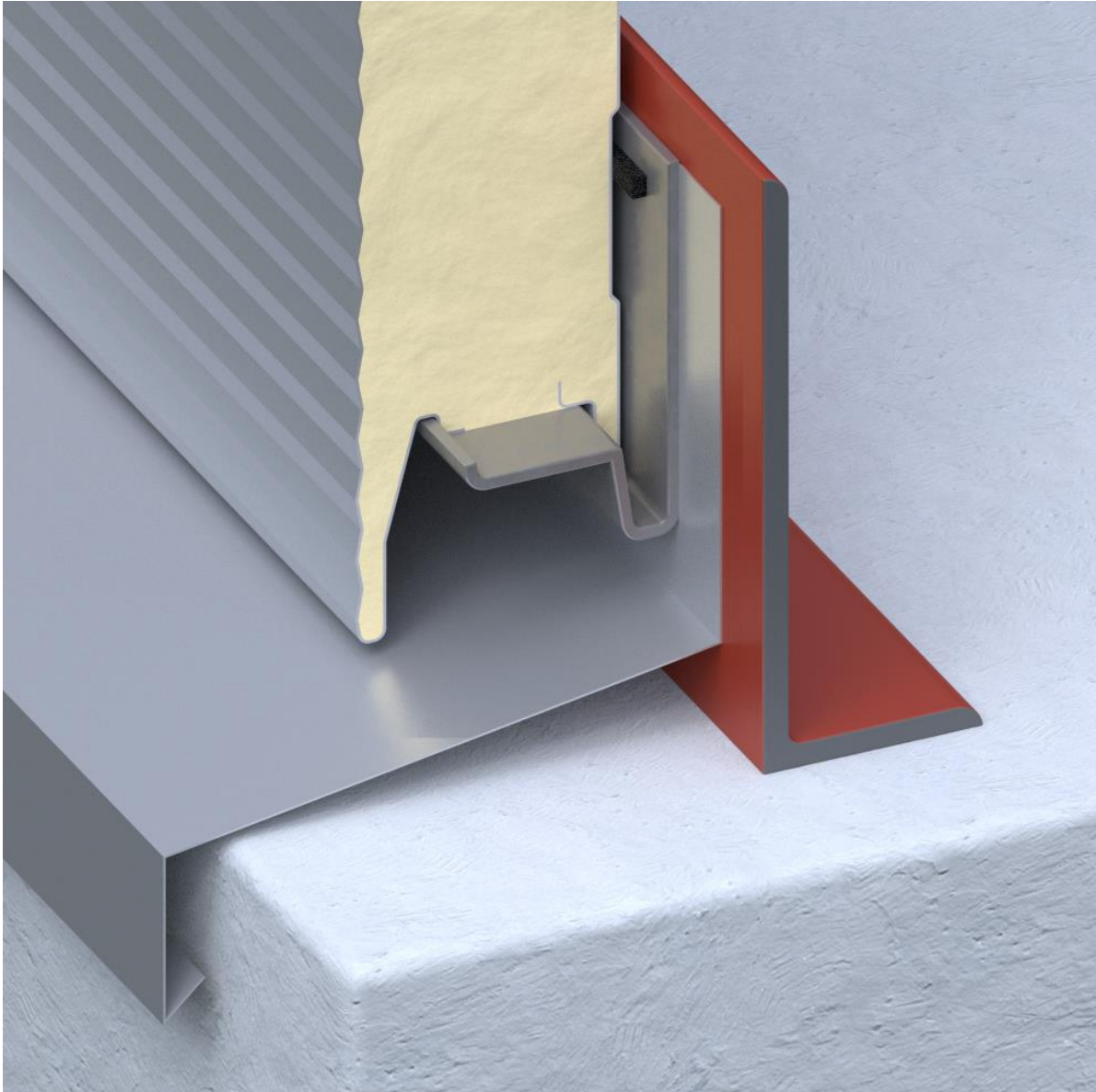

SPV 04mp

Enganche paneles con estructura de hormigón tipo 1

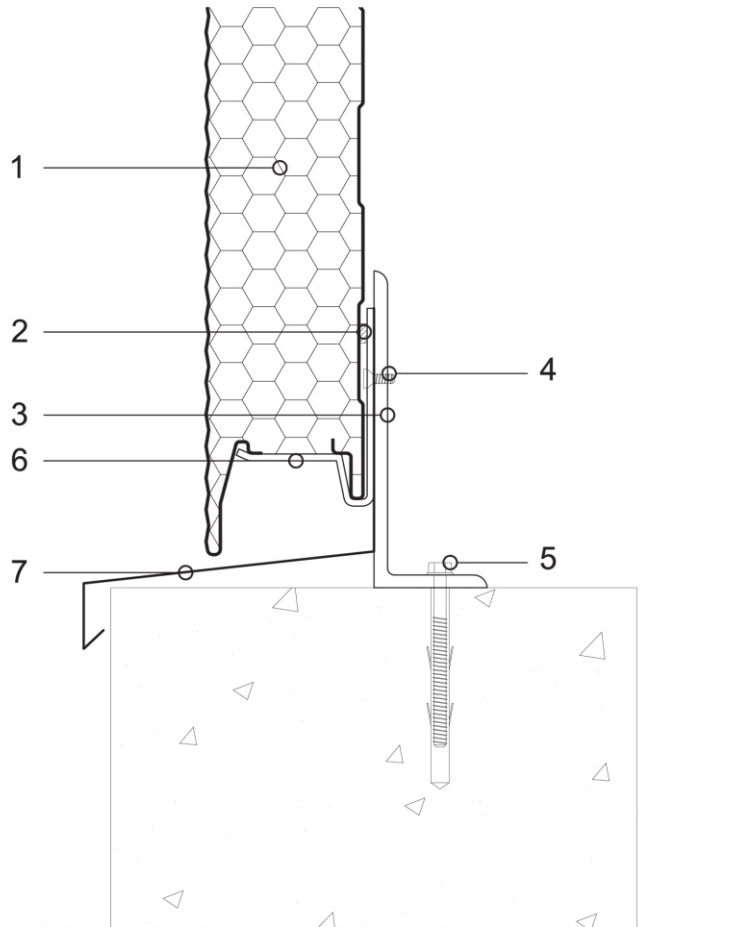

Es tarea del proyectista evaluar la necesidad de introducir otros elementos de guarnición y/o cierre, incluso cuando no se detallan en el dibujo.

Leyenda

1	Panel de pared IsoCindu
2	Junta adhesiva
3	Soporte en L de acero
4	Tomillo de fijación con cabeza avellanada
5	Tomillo de fijación soporte en L de acero
6	Soporte especial de acero
7	Rematería del goterón

ATENCIÓN: la solución propuesta no constituye un proyecto, y debe ser examinada y evaluada preventivamente por el proyectista o por la dirección de obra. El presente tratado es propiedad exclusiva de ISOPAN S.p.A. y se prohíbe la reproducción, incluso parcial, de los contenidos sin la autorización escrita del autor. Para la elección del tipo de fijación, remítase a la ficha para la selección del tipo de tornillo; para la elección de la longitud del tornillo, remítase a la ficha para la correcta longitud del tornillo.

**VERTICAL BUTT JOINT**

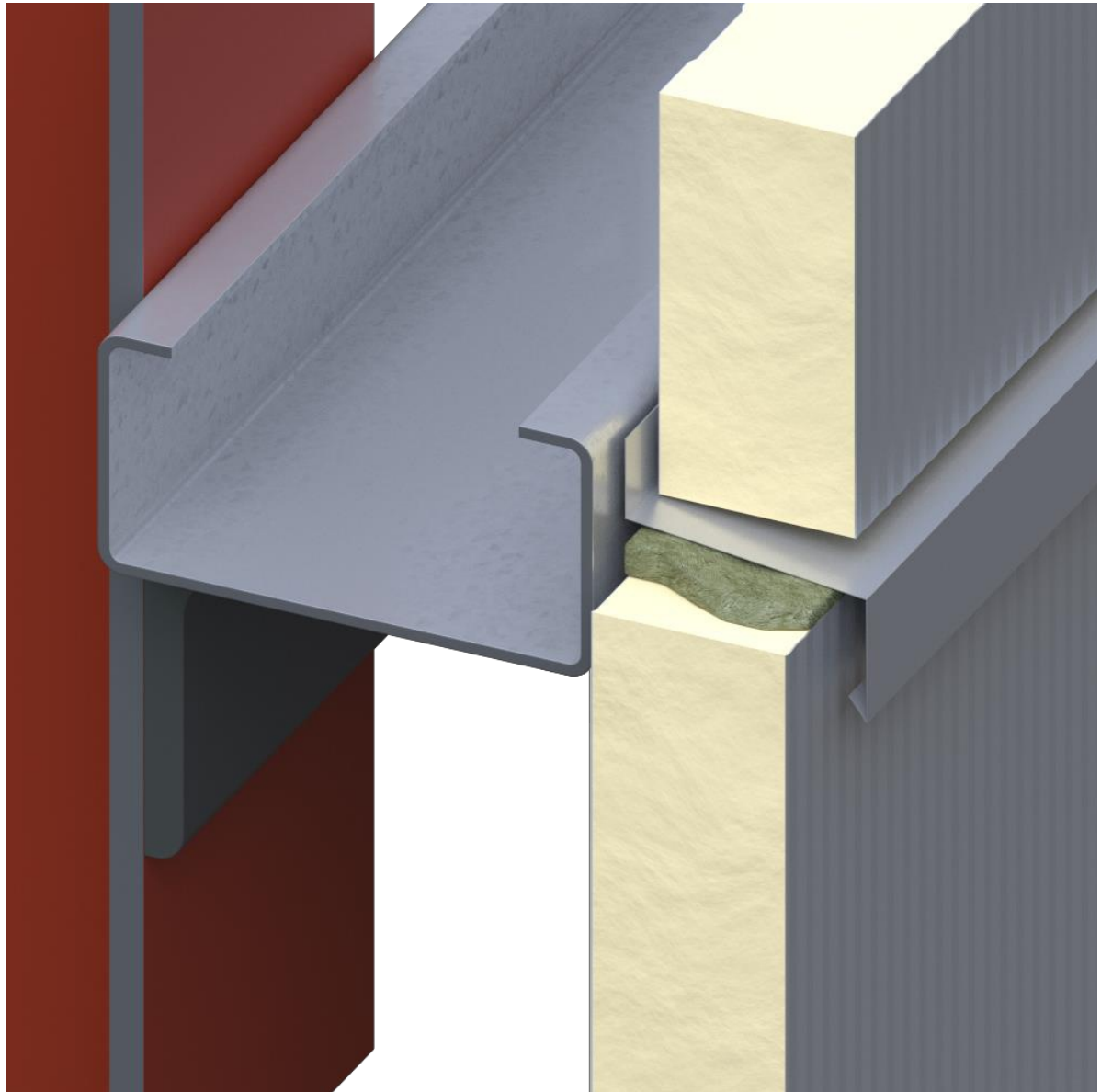

SPV 22

## Enganche paneles pared a la estructura de acero tipo 7

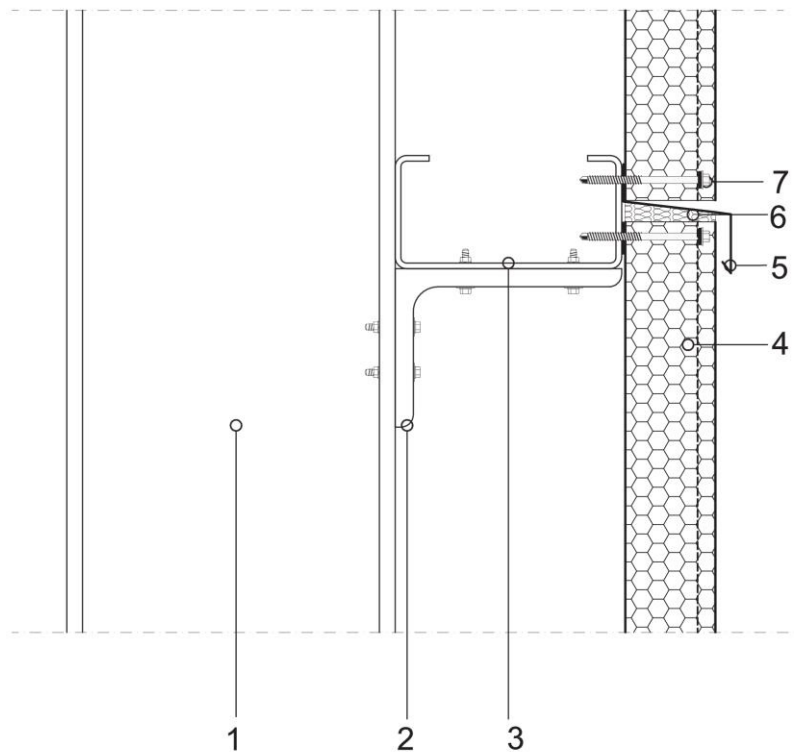

Es tarea del proyectista evaluar la necesidad de introducir otros elementos de guarnición y/o cierre, incluso cuando no se detallan en el dibujo.

### Leyenda

1	Estructura portante de acero
2	Perfil en L
3	Perfil plegado a presión en C
4	Panel de pared IsoCindu (ijación escondida)
5	Moldura del goterón
6	Aislante de lana mineral
7	Tornillo de fijación panel

ATENCIÓN: la solución propuesta no constituye un proyecto, y debe ser examinada y evaluada preventivamente por el proyectista o por la dirección de obra. El presente tratado es propiedad exclusiva de ISOPAN S.p.A. y se prohíbe la reproducción, incluso parcial, de los contenidos sin la autorización escrita del autor. Para la elección del tipo de fijación, remítase a la ficha para la selección del tipo de tornillo; para la elección de la longitud del tornillo, remítase a la ficha para la correcta longitud del tornillo.



**IsoCindu México**

Av. Libre Comercio #137  
Puerto Interior Santa Fe III  
Silao Gto. C.P. 36275  
T. +52 472 800 7241

**Manni Green Tech USA**

179 Hughes Landing Blvd  
Suite 400, The woodlands TX  
TX 77398  
T. (281) 747-5588

**Manni Green Tech USA**

77530 Enfield Lane,  
Building D, Suite D2,  
Palm Desert, California, 92211  
T. (281) 747-5588

**ISOPAN IBERICA**  
Terragona | Spain

**ITALY**  
**ISOPAN SPA**  
Verona | Italy  
Frosinone | Italy

**ISOPAN EST**  
Popești Leordeni | Romania

**ISOPAN Manni Group CZ**  
Praha | Czech Republic

**ISOPAN FRANCE**  
Mérignac | France